

PLY GEM WINDOWS *PERSPECTIVE Multi-Slide Patio Door (IMPACT)*

NOTES:

1. THIS INSTALLATION HAS BEEN EVALUATED FOR USE IN LOCATIONS ADHERING TO THE FLORIDA BUILDING CODE OUTSIDE THE HVHZ, AND WHERE PRESSURE REQUIREMENTS AS DETERMINED BY ASCE 7 MINIMUM DESIGN LOADS FOR BUILDINGS AND OTHER STRUCTURES DO NOT EXCEED THE DESIGN PRESSURE RATINGS HEREIN.
2. THIS PRODUCT IS MISSILE LEVEL D, WIND ZONE 3 IMPACT RESISTANT. WHEN USED IN WIND ZONE 3 OR BELOW AREAS, THIS PRODUCT DOES NOT REQUIRE THE USE OF APPROVED IMPACT PROTECTIVE DEVICES (SHUTTERS).
3. ANCHOR TYPE, SIZE, SPACING, EMBEDMENT, AND EDGE DISTANCE SHALL BE AS SPECIFIED IN THESE DRAWINGS. USE APPROPRIATE ANCHORAGE FROM TABLE 1 AND TABLE 2 ACCORDING TO SUBSTRATE TYPE. A MINIMUM CENTER-TO-CENTER SPACING SHALL BE MAINTAINED BETWEEN ALL INSTALLATION FASTENERS IN ANY DIRECTION.
4. ANCHOR EMBEDMENT TO SUBSTRATE SHALL BE BEYOND WALL DRESSING OR STUCCO. FOR MASONRY OPENINGS WITH WOOD BUCKS LESS THAN 1-1/2" THICK, EMBEDMENT SHALL BE BEYOND WOOD BUCKS, IF USED, AND INTO MASONRY SUBSTRATE. WOOD BUCKS WITH MASONRY ARE OPTIONAL.
5. WOOD, METAL, OR MASONRY OPENINGS, BUCKS, AND BUCK FASTENERS, BY OTHERS, SHALL BE PROPERLY DESIGNED AND INSTALLED BY OTHERS TO TRANSFER SUPERIMPOSED LOADS TO THE STRUCTURE. ADEQUACY OF THE STRUCTURE TO RECEIVED THESE LOADS SHALL BE VERIFIED BY THE CONTRACTOR OR AUTHORITY HAVING JURISDICTION (AHJ).
6. IT IS THE RESPONSIBILITY OF THE ARCHITECT OR ENGINEER OF RECORD OR AS APPROVED BY THE AHJ TO SELECT PLY GEM PRODUCTS TO MEET ALL APPLICABLE LOCAL LAWS, BUILDING CODES, ORDINANCES, OR OTHER SAFETY REQUIREMENTS FOR EACH INSTALLATION.
7. SHIMS ARE REQUIRED WHERE GAPS OF GREATER THAN 1/16" EXIST BETWEEN OPENING AND FRAME. MAX. SHIM STACK IS 1/4". SHIMS SHALL BE LOAD-BEARING AND CAPABLE OF TRANSFERRING LOADS TO THE SUBSTRATE.
8. SEALING AND FLASHING STRATEGIES FOR OVERALL WATER INFILTRATION RESISTANCE OF THE INSTALLED PRODUCT SHALL BE THE RESPONSIBILITY OF OTHERS USING ASTM E 2112 AND IS NOT ADDRESSED BY THIS DOCUMENT.
9. INSTALLED GLAZING SHALL COMPLY WITH ASTM E 1300.
10. ALL FASTENERS PENETRATING INTO PRESSURE TREATED WOOD SHALL BE CAPABLE OF PREVENTING CORROSION DUE TO REACTION WITH PRESSURE TREATMENT CHEMICALS. ANY DISSIMILAR MATERIALS THAT COME INTO CONTACT SHALL BE PROTECTED TO PREVENT REACTIONS IN ACCORDANCE WITH CODE REQUIREMENTS.
11. A WIND LOAD DURATION FACTOR $C_d = 1.6$ WAS USED FOR THE ANALYSIS OF WOOD SCREWS ONLY.
12. PRODUCTS SHALL BE CONSTRUCTED AS SPECIFIED IN TEST REPORTS 11835.06/10/11/12/13/14/15/17/18/19/22-106-II-R0, 11835.02/16-106-II-RI, 11835.05/07-106-II-R2 AND 11835.03-106-I2-RI BY MOLIMO ARCHITECTURAL PRODUCT TESTING.
13. POCKET WALL/CAVITY IS NOT PART OF THIS APPROVAL AND REVIEWED BY THE AUTHORITY HAVING JURISDICTION (AHJ).
14. USE A BACKER ROD ON ALL JOINTS $>3/4"$ DEEP AND/OR WIDER THAN $1/4"$. FINISHED CAULK JOINT SHOULD BE A MINIMUM OF $3/8"$ DEEP.

SIZE CHART					
OVERALL FRAME MAX. SIZE		PERFORMANCE RATING	DESIGN PRESSURE	MIN. SILL RISER	INSTALLATION METHOD
WIDTH	HEIGHT				
281"	120"	LC-PG60	+60/-65 PSF	1-3/4"	NAIL FIN OR THROUGH FRAME

PANEL SIZE CHART				
PANEL CALL SIZE	PANEL MAX. SIZE	D.L.O.		GLAZING DETAIL TYPE
		WIDTH	HEIGHT	
3-0 10-0	37-1/8" x 117-1/8"	28-1/8"	108-1/16"	1 OR 2
4-0 10-0	49-1/8" X 117-1/8"	40-1/8"	108-1/16"	1 OR 2

TABLE OF CONTENTS	
SHEET	SHEET DESCRIPTION
1	SIZE CHART, PANEL SIZE CHART & GENERAL NOTES
2	TABLE 1
3	CONFIGURATIONS & ELEVATIONS
4	HORIZONTAL SECTION DETAILS
5	VERTICAL SECTION DETAILS
6-23	ANCHOR LAYOUTS
24	P-HOOK ANCHOR LAYOUT DETAILS & TABLE 2
25	GLAZING DETAILS & SPLICE DETAILS
26	NAIL FIN SUPPLEMENTAL PATTERN

TITLE: PERSPECTIVE MULTI-SLIDE PATIO DOOR IMPACT SIZE CHART, PANEL SIZE CHART & GENERAL NOTES	DATE				
	DWN BY:	LMH	CHK BY:	SAS	SCALE:
	NO.				NTS
	REVISION DESCRIPTION				

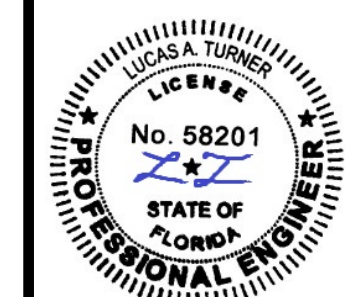

12/12/2023
LUCAS A. TURNER, P.E.
FL PE # 58201
TURNER ENGINEERING & CONSULTING, INC.
(COA # 29779)
2428 OLD NATCHEZ TRACE TRAIL, CAMDEN, TN 38320
PH. 941-380-1574

FL#: **41161**
DWG #: **PGW342**
SHEET **1** - FLOF **26**

PERFORMANCE GRADE LC-PG60 (+60/-65) IMPACT

TABLE I: INSTALLATION FASTENERS TABLE

ID	FRAME LOCATION	SUBSTRATE TYPE	ANCHOR TYPE	MIN. EDGE DISTANCE	MIN. EMBED.	MIN. ON CENTER SPACING	PANEL WIDTH					
							UP TO 3-0 x 10-0 MAX.		UP TO 4-0 x 10-0 MAX.		UP TO 5-0 x 10-0 MAX.	
							HEAD & SILL CLUSTERS QUANTITY	JAMB O.C. SPACING	HEAD & SILL CLUSTERS QUANTITY	JAMB O.C. SPACING	HEAD & SILL CLUSTERS QUANTITY	JAMB O.C. SPACING
A	HEAD/SILL/JAMB	CONCRETE (2 KSI MIN.)	1/4" ITW TAPCON w/ADVANCED THREADFORM TECHNOLOGY COATED CARBON STEEL	1-1/2"	1-3/4"	4"	3	16-3/4"	4	16-3/4"	N/A	
B	JAMBS ONLY	HOLLOW OR GROUT-FILLED CMU (ASTM C-90)	1/4" ITW TAPCON w/ADVANCED THREADFORM TECHNOLOGY COATED CARBON STEEL	2"	1"	4"	N/A	14-3/4"	N/A	14-3/4"	N/A	
C	HEAD/SILL/JAMB	CONCRETE (3.05 KSI MIN.)	1/4" DEWALT ULTRACON+, COATED CARBON STEEL	1"	1-3/8"	4"	5	14-3/4"	7	14-3/4"	N/A	
D	HEAD/SILL/JAMB	CONCRETE (3.05 KSI MIN.)	1/4" DEWALT ULTRACON+, COATED CARBON STEEL	2-1/2"	1-3/8"	4"	3	16-3/4"	4	16-3/4"	N/A	
E	JAMBS ONLY	HOLLOW CMU (ASTM C-90)	1/4" DEWALT ULTRACON+, COATED CARBON STEEL	1"	1-1/4"	3"	N/A	14-3/4"	N/A	14-3/4"	N/A	
F	JAMBS ONLY	HOLLOW CMU (ASTM C-90)	1/4" DEWALT ULTRACON+, COATED CARBON STEEL	2-1/2"	1-1/4"	3"	N/A	16-3/4"	N/A	16-3/4"	N/A	
G	JAMBS ONLY	GROUT-FILLED CMU (ASTM C-90)	1/4" DEWALT ULTRACON+, COATED CARBON STEEL	1"	1-1/4"	4"	N/A	16-3/4"	N/A	16-3/4"	N/A	
H	HEAD/SILL/JAMB	CONCRETE (3 KSI MIN.)	1/4" HILTI KWIK-CON+, COATED CARBON STEEL	2-1/2"	1"	2"	3	16-3/4"	4	16-3/4"	N/A	
I	JAMBS ONLY	HOLLOW OR GROUT-FILLED CMU (ASTM C-90)	1/4" HILTI KWIK-CON+, COATED CARBON STEEL	2-1/2"	1"	4"	N/A	16-3/4"	N/A	16-3/4"	N/A	
J	HEAD/SILL/JAMB	CONCRETE (2.22 KSI MIN.)	#1/4" DEWALT AGGRE-GATOR, 300 STAINLESS STEEL	1-1/2"	1-3/8"	3"	3	16-3/4"	7	16-3/4"	N/A	
K	JAMBS ONLY	HOLLOW OR GROUT-FILLED CMU (ASTM C-90)	#1/4" DEWALT AGGRE-GATOR, 300 STAINLESS STEEL	2"	1-1/4"	3"	N/A	16-3/4"	N/A	16-3/4"	N/A	
L	HEAD/SILL/JAMB	2X MIN. SPRUCE-PINE-FIR WOOD (G>=0.42)	#12 GRADE 5 WOOD SCREW	3/4"	1-1/2"	3"	5	16"	7	16"	N/A	
M	HEAD/SILL/JAMB	2X MIN. SOUTHERN PINE WOOD (G>=0.55)	#12 GRADE 5 WOOD SCREW	3/4"	1-1/2"	3"	5	16"	7	16"	N/A	
N	HEAD/SILL/JAMB	2X MIN. SPRUCE-PINE-FIR WOOD (G>=0.42)	1/4" MASONRY FASTENERS AS LISTED IN THIS TABLE	1"	1-1/2"	3"	5	16"	7	16"	N/A	
O	HEAD/SILL/JAMB	2X MIN. SOUTHERN PINE WOOD (G>=0.55)	1/4" MASONRY FASTENERS AS LISTED IN THIS TABLE	1"	1-1/2"	3"	5	16"	7	16"	N/A	
P	HEAD/SILL/JAMB	16 GAUGE (0.060"), MIN. STEEL STUD, 33 KSI YIELD MIN.	#12-14 ITW TEKS, DEWALT DRIL-FLEX, OR HILTI KWIK-FLEX SELF-DRILLING SCREW	1/2"	FULL PLUS 3 THREADS MIN.	3"	5	16-3/4"	7	16-3/4"	N/A	
Q	HEAD/SILL/JAMB	1/8" ALUM. 6063-T5 MIN. OR 1/8" STEEL 36 KSI MIN.	#12-14 GRADE 5 SELF-TAPPING/DRILLING SCREW	1/2"	FULL PLUS 3 THREADS MIN.	3"	5	16-3/4"	7	16-3/4"	N/A	

NOTES: -ALL SCREWS SHALL BE PAN OR HEX WASHER HEAD.
 -PRE-DRILLING FOR ANCHORS INTO WOOD IS RECOMMENDED.
 -SEE SHEET 25 FOR P-HOOK DETAILS.
 -CONCRETE/MASONRY SHALL NOT BE CRACKED.

Ply Gem
 WINDOWS & DOORS
 Part of the Cornerstone Building Brands Family
 433 N. MAIN ST.,
 PO BOX 559,
 ROCKY MOUNT, VA 24151
 PH: 540-484-6348
 FX: 540-484-6683

TITLE: PERSPECTIVE MULTI-SLIDE PATIO DOOR IMPACT TABLE I	DATE				
	BY				
	REVISION DESCRIPTION				
	NO.				
DATE: 08/25/23	DWN BY: LMH	CHK BY: SAS	SCALE: NTS		



12/12/2023
 LUCAS A. TURNER, P.E.
 FL PE # 58201
 TURNER ENGINEERING &
 CONSULTING, INC.
 (COA # 29779)
 2428 OLD NATCHEZ TRACE
 TRAIL, CAMDEN, TN 38320
 PH. 941-380-1574

FL#: **41161**
 DWG #: **PGW342**
 SHEET: **2 OF 26**

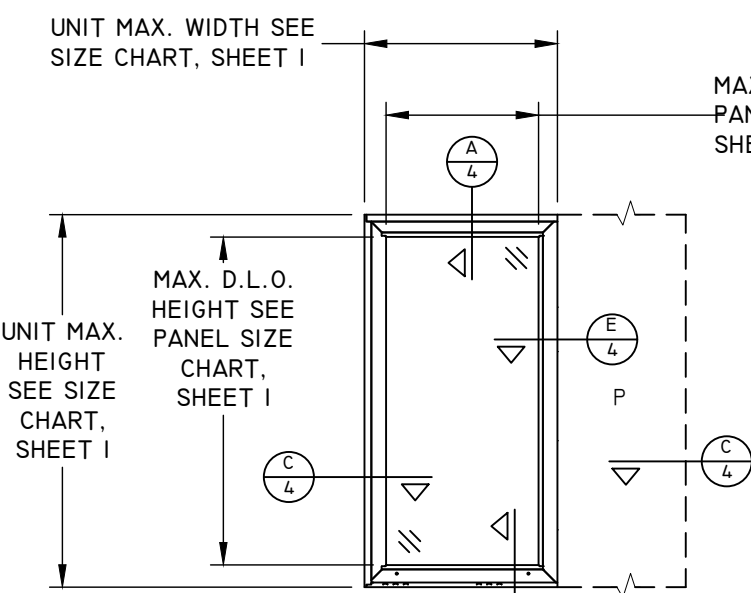

TYPICAL ELEVATION
XP or PX

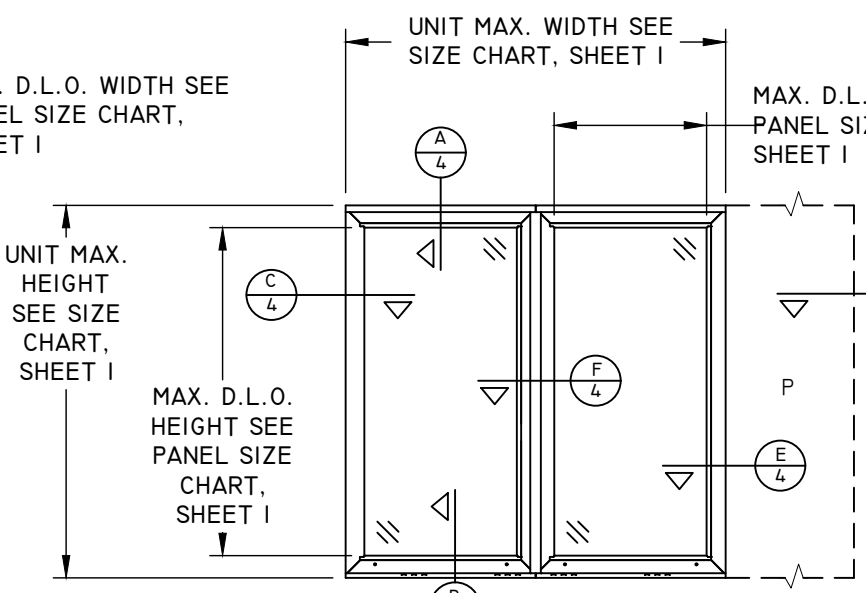

TYPICAL ELEVATION
XO, OX, XX, PXX, XXP or PX-XP

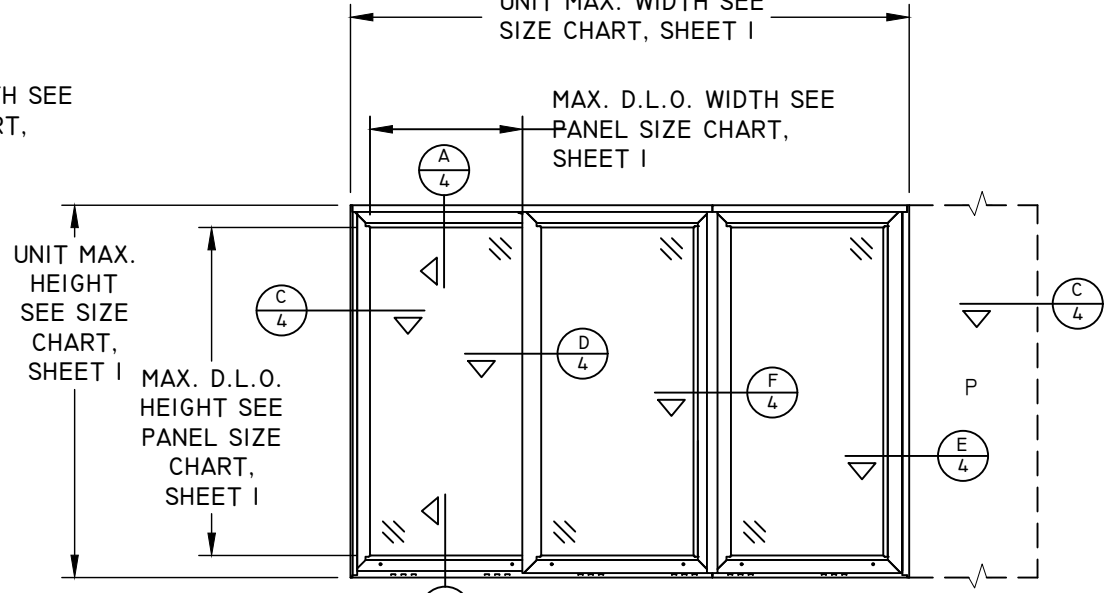

TYPICAL ELEVATION
XXXP, PXXX, XXXL, XXO, OXX, OX-O or O-XO

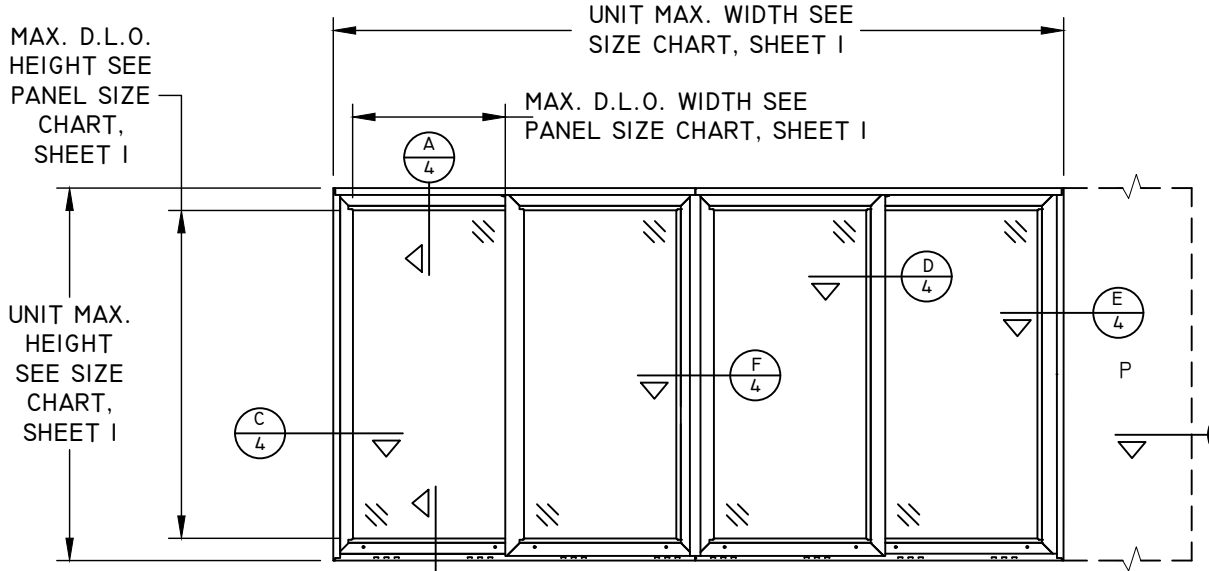

TYPICAL ELEVATION
XXXXP, PXXXX, XXXL, XXXO, OXXX, PXX-XXP or OX-XO

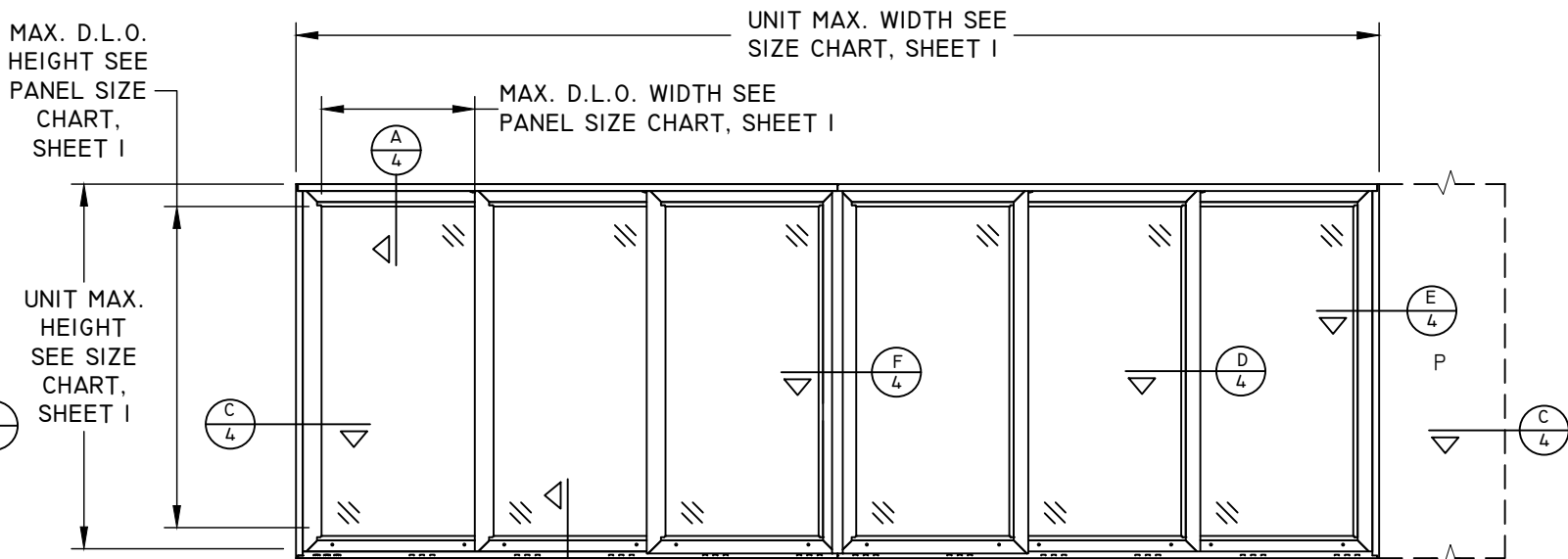

TYPICAL ELEVATION
OXX-XXO or PXXX-XXXP

2 TRACK CONFIGURATIONS		
CONFIGURATION	# OF TRACKS	# OF PANELS
XP	2	1
PX	2	1
XXP	2	2
PXX	2	2
XX	2	2
XO	2	2
OX	2	2
PX-XP	2	2
OX-O	2	3
O-XO	2	3
PXX-XXP	2	4
OX-XO	2	4

3 TRACK CONFIGURATIONS		
CONFIGURATION	# OF TRACKS	# OF PANELS
XXXP	3	3
PXXX	3	3
XXX	3	3
XXO	3	3
OXX	3	3
PXXX-XXXP	3	6
OXX-XXO	3	6

4 TRACK CONFIGURATIONS		
CONFIGURATION	# OF TRACKS	# OF PANELS
XXXXP	4	4
PXXXX	4	4
XXXX	4	4
XXXO	4	4
OXXX	4	4

CONFIGURATION NOTES	
CODE	PANEL TYPE
O	FIXED PANEL
X	OPERATING PANEL
P	POCKET
-	BI-PARTING

CONFIGURATION NOTES:
- ALL CONFIGURATIONS ARE AVAILABLE WITH POCKET AT EITHER OR BOTH JAMB LOCATIONS.

TITLE: PERSPECTIVE MULTI-SLIDE PATIO DOOR IMPACT CONFIGURATIONS & ELEVATIONS	DATE			
	BY			
	REVISION DESCRIPTION			
NO.				
DATE: 08/25/23	DWN BY: LMH	CHK BY: SAS	SCALE: NTS	

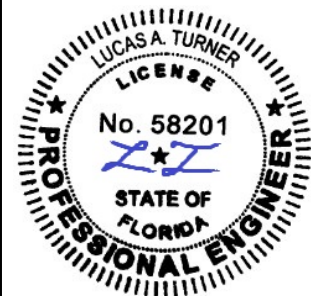

12/12/2023
LUCAS A. TURNER, P.E.
FL PE # 58201
TURNER ENGINEERING & CONSULTING, INC.
(COA # 29779)
2428 OLD NATCHEZ TRACE TRAIL, CAMDEN, TN 38320
PH. 941-380-1574

FL#: **41161**
DWG #: **PGW342**
SHEET: **3 OF 26**

HORIZONTAL SECTION

O-XO SHOWN
Unit Width

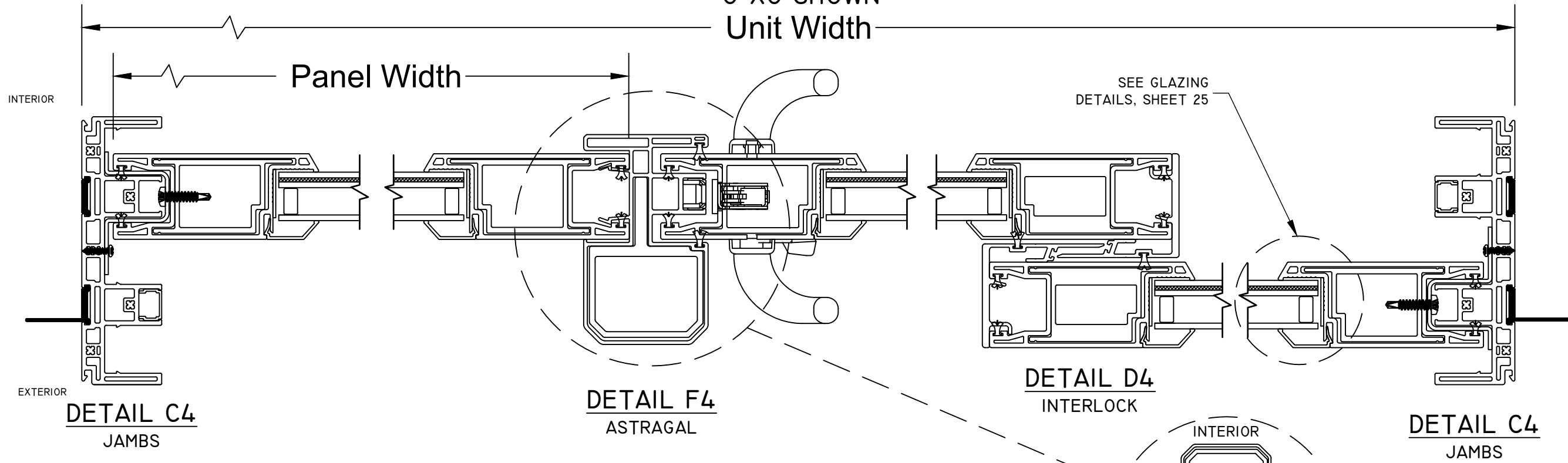

DP60 (+60/-65) IMPACT

HORIZONTAL SECTION

PXXX SHOWN

Unit Width

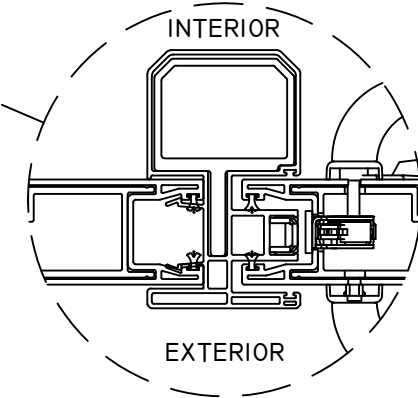
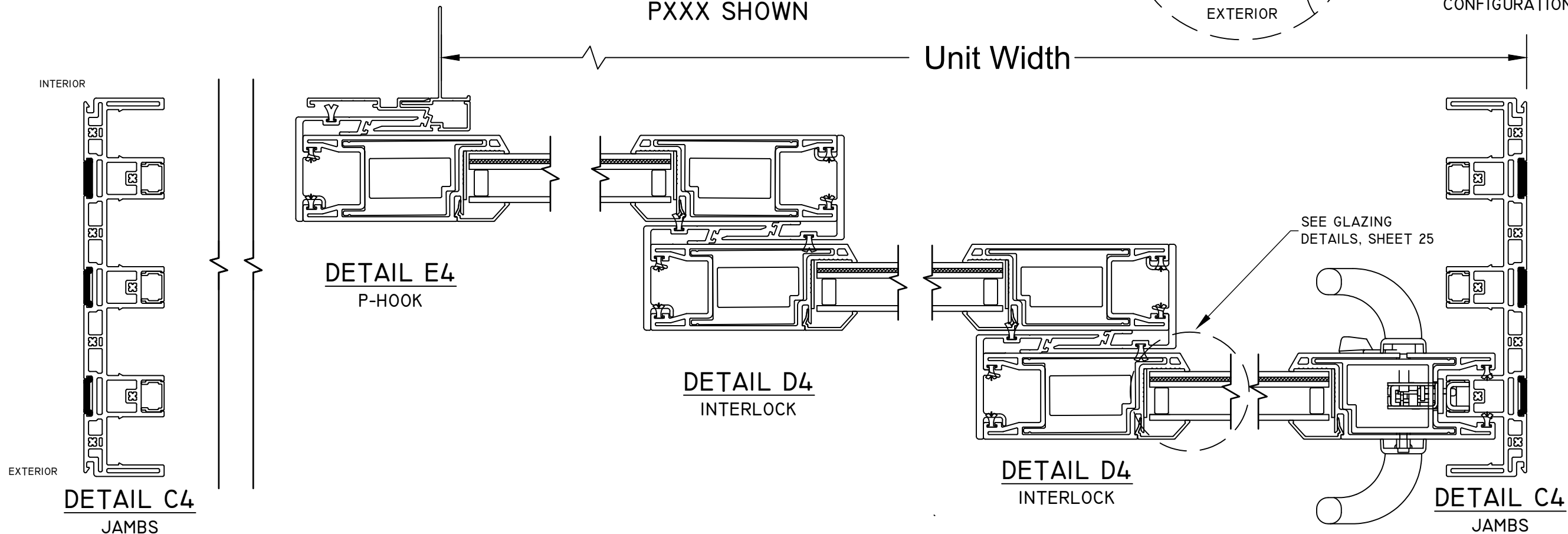

ASTRAGAL MAY BE
MOUNTED TO INTERIOR
ON REVERSE STACK
AND SOME POCKET
CONFIGURATIONS.

TITLE: PERSPECTIVE MULTI-SLIDE PATIO DOOR IMPACT HORIZONTAL SECTION DETAILS	DATE	BY	DATE
	NO.	REVISION DESCRIPTION	
DATE: 08/25/23	DWN BY: LMH	CHK BY: SAS	SCALE: NTS



12/12/2023
LUCAS A. TURNER, P.E.
FL PE # 58201
TURNER ENGINEERING &
CONSULTING, INC.
(COA # 29779)
2428 OLD NATCHEZ TRACE
TRAIL, CAMDEN, TN 38320
PH. 941-380-1574

FL#:	41161
DWG #:	PGW342
SHEET:	4 OF 26

DP60 (+60/-65) IMPACT

Ply Gem
WINDOWS & DOORS
Part of the Cornerstone Building Brands Family
433 N. MAIN ST.,
PO BOX 559,
ROCKY MOUNT, VA 24151
PH: 540-484-6348
FX: 540-484-6683

DETAIL A4
HEAD

INTERIOR

DETAIL A4
HEAD

INTERIOR

Unit
Height

Panel
Height

Daylight
Opening
Height

SEE GLAZING DETAIL,
SHEET 25

SEALANT

3-1/2" TOTAL
SILL HEIGHT
WITH
1-3/4" SILL RISER

SEALANT

3-1/2" TOTAL
SILL HEIGHT
WITH
1-3/4" SILL RISER

DETAIL B4
SILL

EXTERIOR

DETAIL B4
SILL

EXTERIOR

VERTICAL SECTION
2 TRACK NAIL FIN SHOWN

VERTICAL SECTION
3 TRACK BOX FRAME SHOWN

TITLE: PERSPECTIVE MULTI-SLIDE PATIO DOOR IMPACT VERTICAL SECTION DETAILS	DATE	DATE		
	DWN BY: LMH	BY		
	CHK BY: SAS	REVISION DESCRIPTION		
DATE: 08/25/23	NO.			
	SCALE:	NTS		



12/12/2023
LUCAS A. TURNER, P.E.
FL PE # 58201
TURNER ENGINEERING &
CONSULTING, INC.
(COA # 29779)
2428 OLD NATCHEZ TRACE
TRAIL, CAMDEN, TN 38320
PH. 941-380-1574

FL#: **41161**

DWG #: **PGW342**

SHEET: **5 OF 26**

2 TRACK ANCHOR LAYOUT DETAILS WITH NAIL FIN - HEAD

HEAD - DP60 (+60/-65) IMPACT

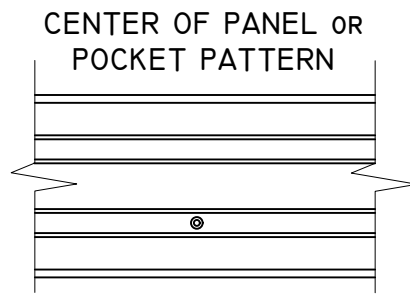
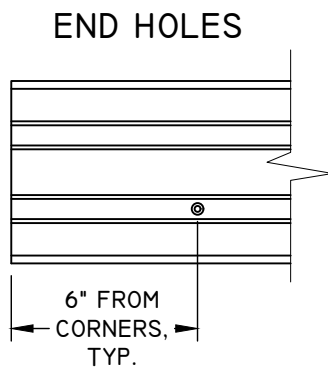
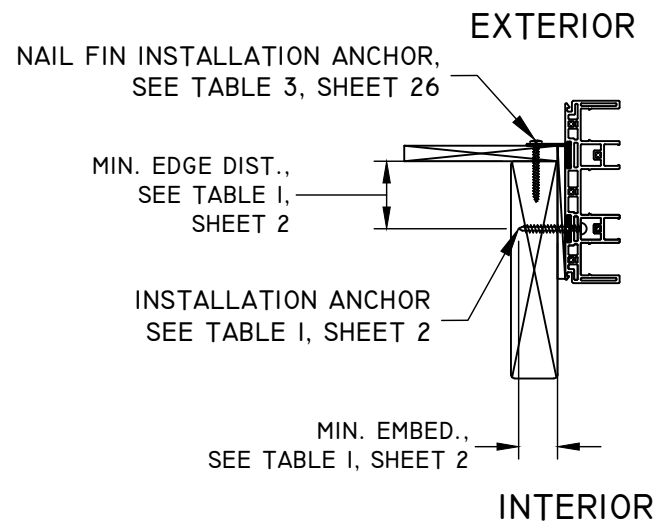

3-0 MAX. PANEL SIZE INTERLOCK / ASTRAGAL PATTERN
SEE TABLE 1, SHEET 2: ANCHORS L & M

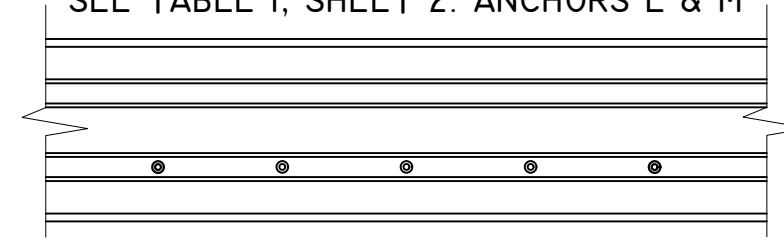

4-0 MAX. PANEL SIZE INTERLOCK / ASTRAGAL PATTERN
SEE TABLE 1, SHEET 2: ANCHORS L & M

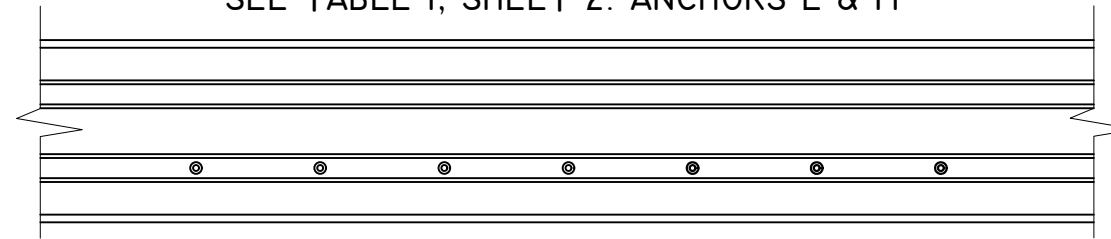

3-0 MAX. PANEL TYPICAL PATTERN AT SPLICE
SEE TABLE 1, SHEET 2: ANCHORS L & M
4" MIN. ON CENTER SPACING

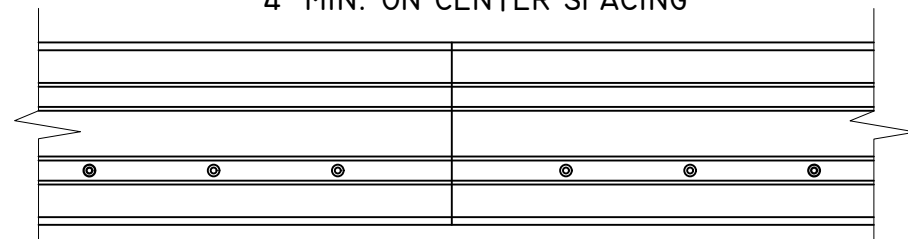

4-0 MAX. PANEL TYPICAL PATTERN AT SPLICE
SEE TABLE 1, SHEET 2: ANCHORS L & M
4" MIN. ON CENTER SPACING

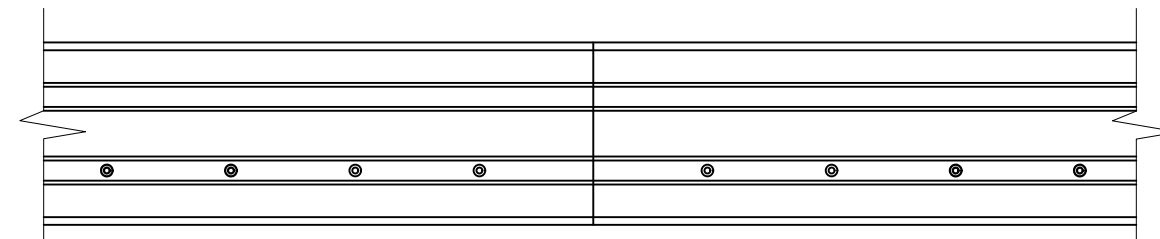

NOTES:

1. UNIT MUST BE INSTALLED WITH ANCHORS THROUGH FRAME AND THROUGH NAIL FIN SIMULTANEOUSLY.
2. 2X MIN. WOOD OR METAL INSTALLATIONS ONLY. WOOD OR METAL MAY BE INSTALLED BY OTHERS OVER CONCRETE/MASONRY NOT SHOWN.
3. SEE SHEET 26 FOR SUPPLEMENTAL INSTALLATION PATTERN THROUGH NAIL FIN, DETAIL A.
4. FRAME INSTALLATION HOLES ARE FABRICATED BY MANUFACTURER.
5. SEE TABLE 1, SHEET 2 FOR FASTENER MINIMUM EDGE DISTANCE, EMBEDMENT AND ON CENTER SPACING.
6. 1/4" MAX. SHIM STACK.
7. SPLICE DETAIL, SEE SHEET 25.

TITLE: PERSPECTIVE MULTI-SLIDE PATIO DOOR IMPACT ANCHOR LAYOUT	DATE			
	BY			
	REVISION DESCRIPTION			
NO.				
DATE: 08/25/23	DWN BY: LMH	CHK BY: SAS	SCALE: NTS	

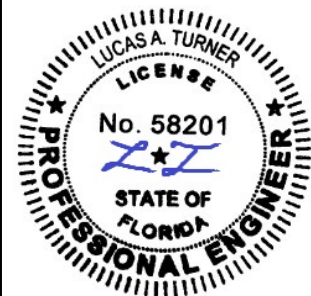

12/12/2023
LUCAS A. TURNER, P.E.
FL PE # 58201
TURNER ENGINEERING & CONSULTING, INC.
(COA # 29779)
2428 OLD NATCHEZ TRACE
TRAIL, CAMDEN, TN 38320
PH. 941-380-1574

FL#: 41161
DWG #: PGW342
SHEET: 6 OF 26

2 TRACK ANCHOR LAYOUT DETAILS WITH NAIL FIN - SILL

SILL - DP60 (+60/-65) IMPACT

PlyGem
WINDOWS & DOORS
Part of the Cornerstone Building Brands Family
433 N. MAIN ST.,
PO BOX 559,
ROCKY MOUNT, VA 24151
PH: 540-484-6348
FX: 540-484-6683

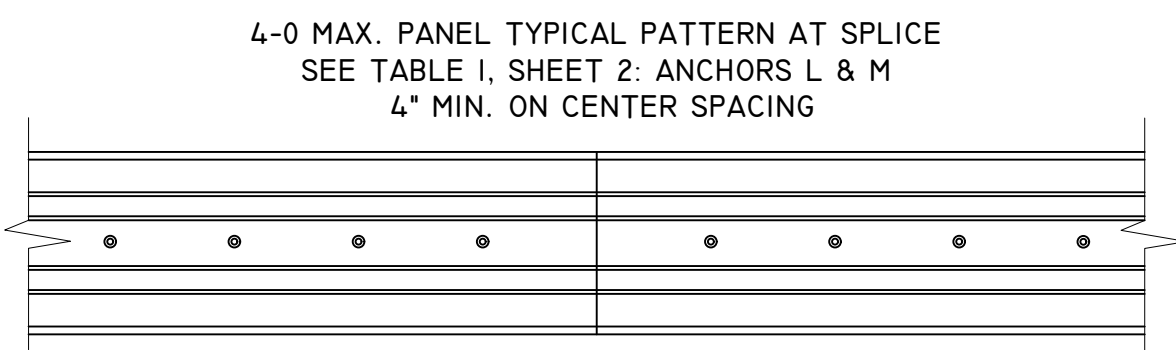
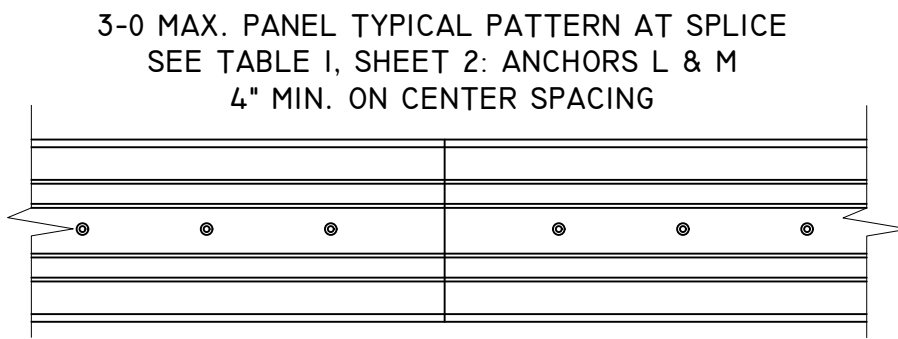
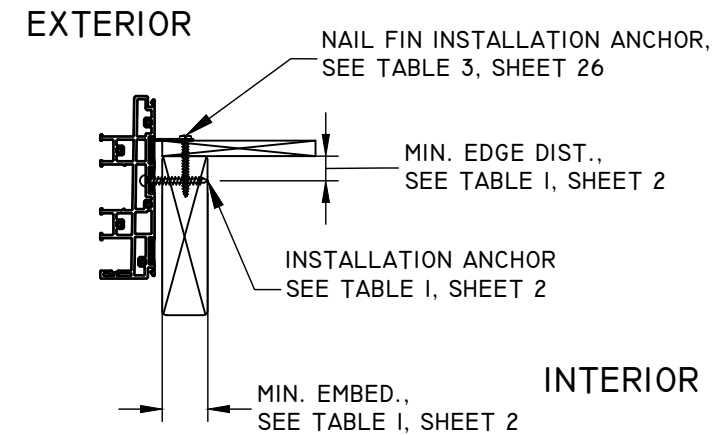
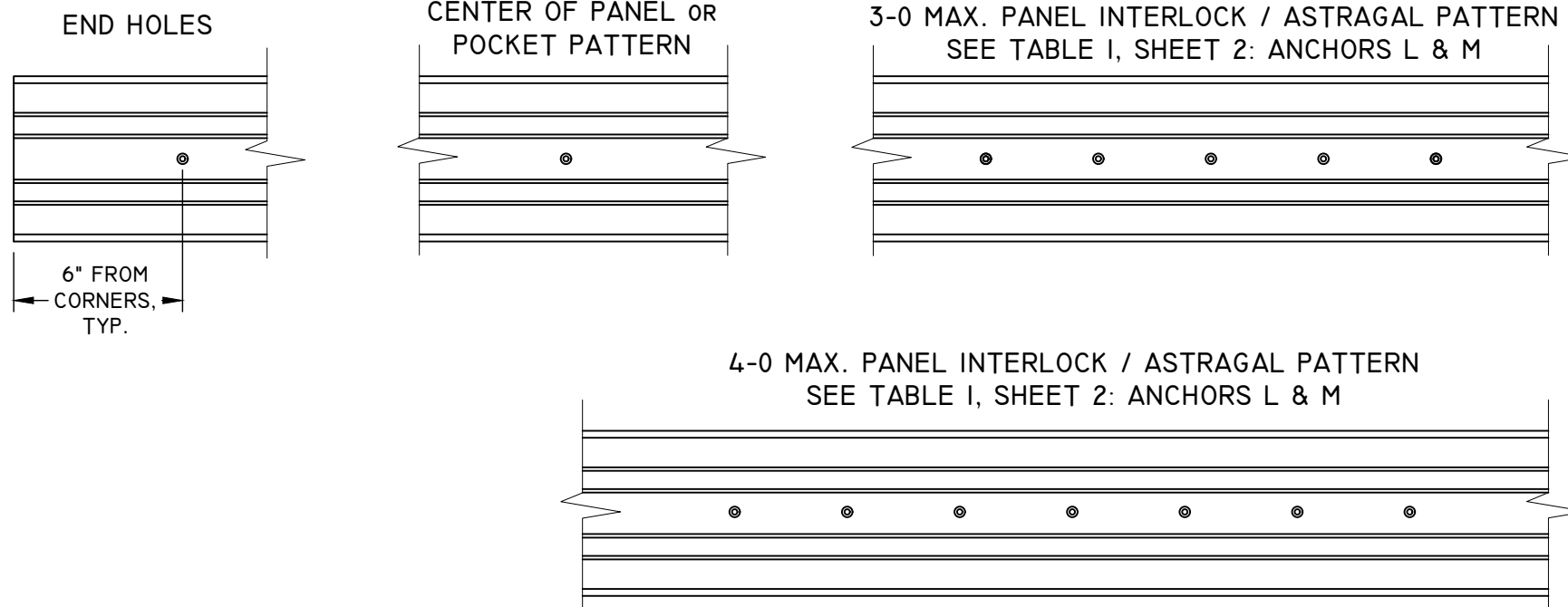

- NOTES:**
1. UNIT MUST BE INSTALLED WITH ANCHORS THROUGH FRAME AND THROUGH NAIL FIN SIMULTANEOUSLY.
 2. 2X MIN. WOOD OR METAL INSTALLATIONS ONLY. WOOD OR METAL MAY BE INSTALLED BY OTHERS OVER CONCRETE/MASONRY, NOT SHOWN.
 3. SEE SHEET 26 FOR SUPPLEMENTAL INSTALLATION PATTERN THROUGH NAIL FIN, DETAIL B - ALTERNATE.
 4. FRAME INSTALLATION HOLES ARE FABRICATED BY MANUFACTURER.
 5. SEE TABLE I, SHEET 2 FOR FASTENER MINIMUM EDGE DISTANCE, EMBEDMENT AND ON CENTER SPACING.
 6. 1/4" MAX. SHIM STACK.
 7. SPLICE DETAIL, SEE SHEET 25.
 8. FILL ALL PRE-DRILLED INSTALLATION HOLES WITH EXTERIOR GRADE SEALANT PRIOR TO INSERTING SCREWS AND APPLY SEALANT OVER THE HEAD OF SCREWS ONCE PROPERLY SEATED.

TITLE: PERSPECTIVE MULTI-SLIDE PATIO DOOR IMPACT ANCHOR LAYOUT	DATE			
	BY			
NO.	REVISION DESCRIPTION			
DATE: 08/25/23	DWN BY: LMH	CHK BY: SAS	SCALE: NTS	

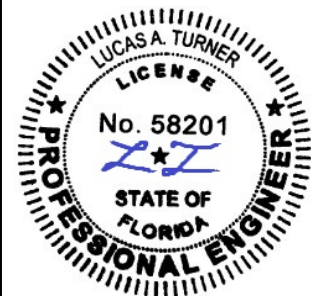

12/12/2023
LUCAS A. TURNER, P.E.
FL PE # 58201
TURNER ENGINEERING & CONSULTING, INC.
(COA # 29779)
2428 OLD NATCHEZ TRACE
TRAIL, CAMDEN, TN 38320
PH. 941-380-1574

FL#: 41161
DWG #: PGW342
SHEET: 7 OF 26

2 TRACK ANCHOR LAYOUT DETAILS WITH NAIL FIN - JAMBS

JAMB - DP60 (+60/-65) IMPACT

SEE TABLE I, SHEET 2:
ANCHOR ID - L & M

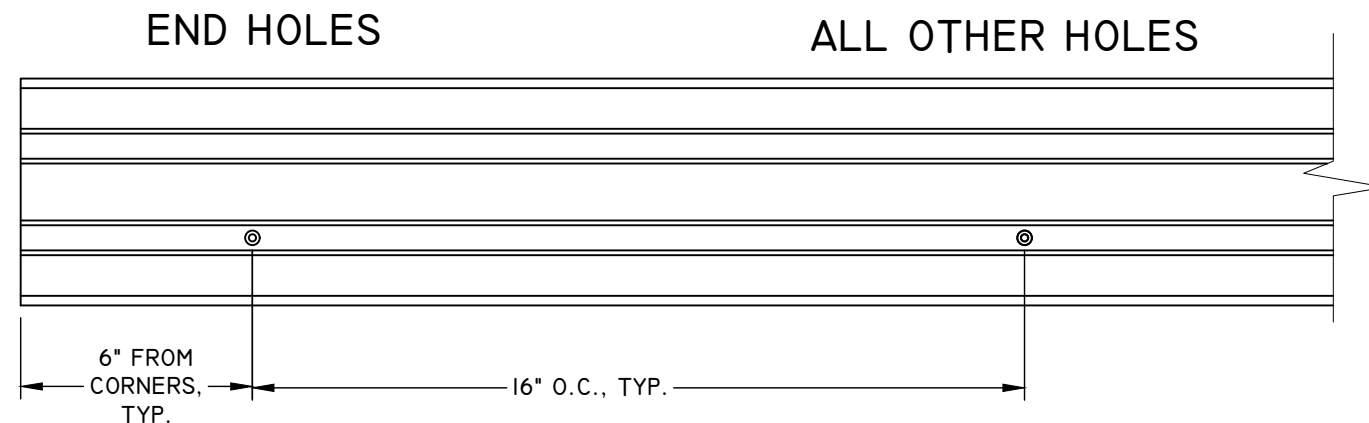

EXTERIOR

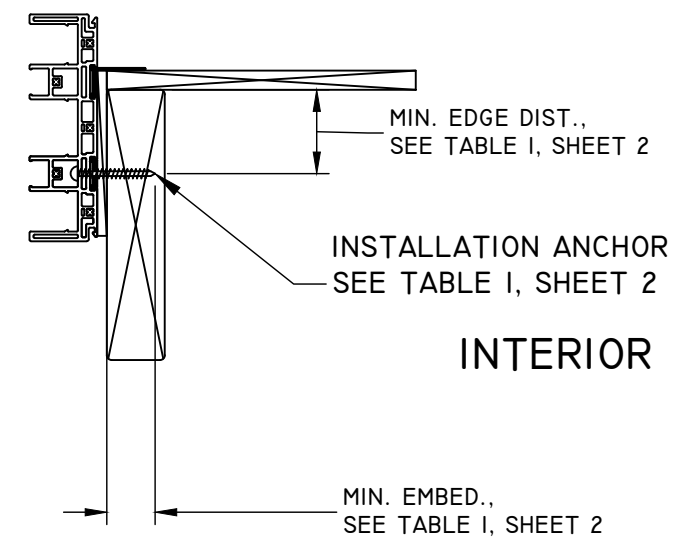

INTERIOR

NOTES:

1. INSTALLATION HOLES ARE FABRICATED BY MANUFACTURER.
2. SEE TABLE I, SHEET 2 FOR FASTENER MINIMUM EDGE DISTANCE, EMBEDMENT AND ON CENTER SPACING.
2. 2X MIN. WOOD OR METAL INSTALLATIONS ONLY. WOOD OR METAL MAY BE INSTALLED BY OTHERS OVER CONCRETE/MASONRY NOT SHOWN.
3. 1/4" MAX. SHIM STACK.
4. FILL LEFT & RIGHT PRE-DRILLED JAMB INSTALLATION HOLES - 6" FROM CORNER OF SILL ONLY, WITH EXTERIOR GRADE SEALANT PRIOR TO INSERTING SCREWS AND APPLY SEALANT OVER THE HEAD OF THE SCREWS ONCE PROPERLY SEATED.

TITLE: PERSPECTIVE MULTI-SLIDE PATIO DOOR IMPACT ANCHOR LAYOUT	DATE			
	BY			
NO.	REVISION DESCRIPTION			
DATE: 08/25/23	DWN BY: LMH	CHK BY: SAS	SCALE: NTS	

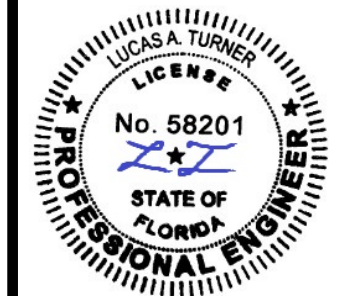

12/12/2023
LUCAS A. TURNER, P.E.
FL PE # 58201
TURNER ENGINEERING &
CONSULTING, INC.
(COA # 29779)
2428 OLD NATCHEZ TRACE
TRAIL, CAMDEN, TN 38320
PH. 941-380-1574

FL#:	41161
DWG #:	PGW342
SHEET:	8 OF 26

2 TRACK ANCHOR LAYOUT DETAILS BOX FRAME - HEAD

HEAD - DP60 (+60/-65) IMPACT

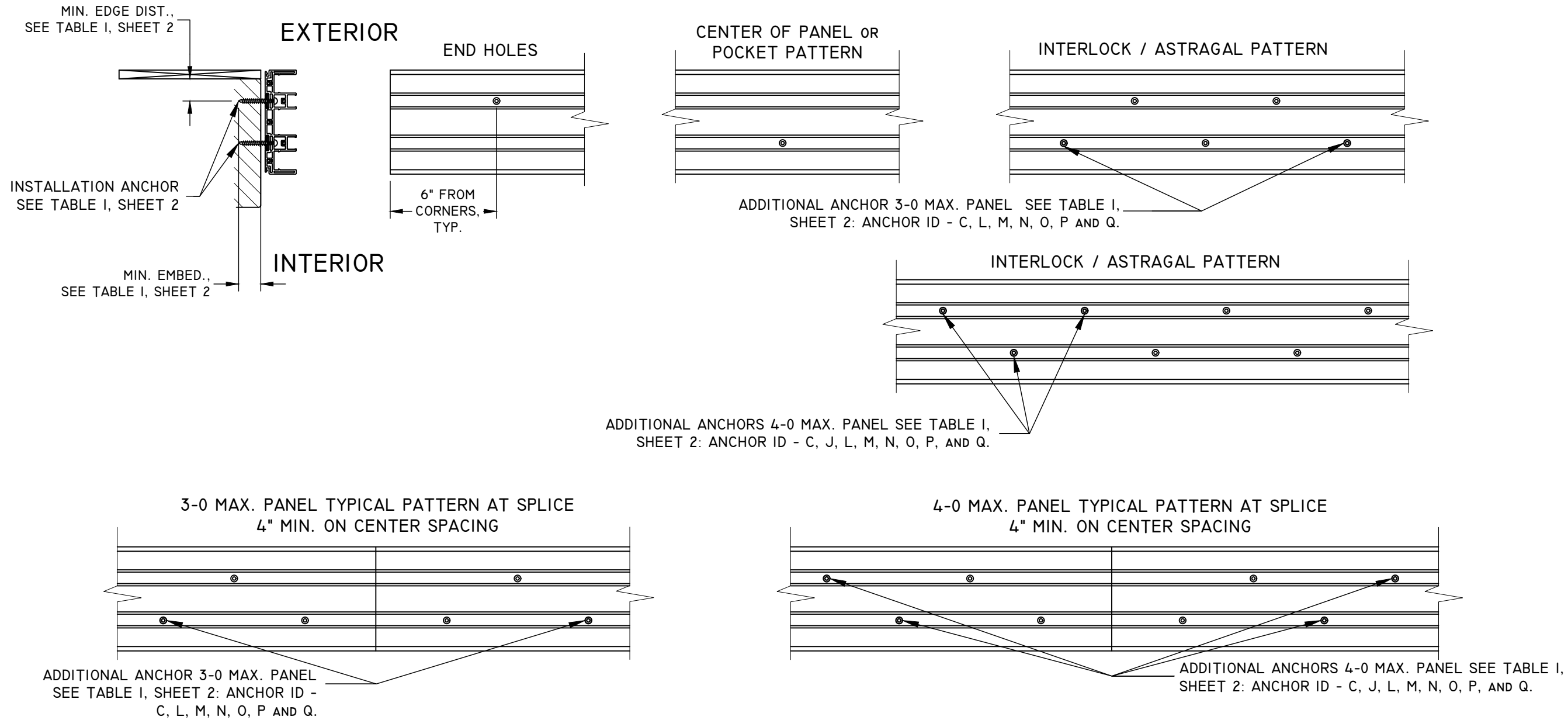

NOTES:

1. INSTALLATION HOLES ARE FABRICATED BY MANUFACTURER.
2. SEE TABLE I, SHEET 2 FOR FASTENER MINIMUM EDGE DISTANCE, EMBEDMENT AND ON CENTER SPACING.
3. IX WOOD BUCK BY OTHERS IS OPTIONAL FOR MASONRY APPLICATIONS.
4. 1/4" MAX. SHIM STACK.
5. SPLICE DETAIL, SEE SHEET 25.

TITLE: PERSPECTIVE MULTI-SLIDE PATIO DOOR IMPACT ANCHOR LAYOUT	DATE			
	BY			
NO.	REVISION DESCRIPTION			
DATE: 08/25/23	DWN BY: LMH	CHK BY: SAS	SCALE: NTS	

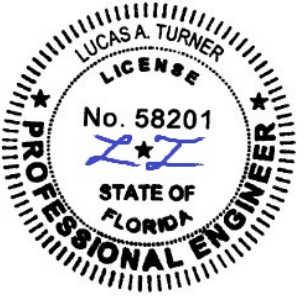

12/12/2023
LUCAS A. TURNER, P.E.
FL PE # 58201
TURNER ENGINEERING &
CONSULTING, INC.
(COA # 29779)
2428 OLD NATCHEZ TRACE
TRAIL, CAMDEN, TN 38320
PH. 941-380-1574

FL#:	41161
DWG #:	PGW342
SHEET:	9 OF 26

2 TRACK ANCHOR LAYOUT DETAILS BOX FRAME - SILL

SILL - DP60 (+60/-65) IMPACT

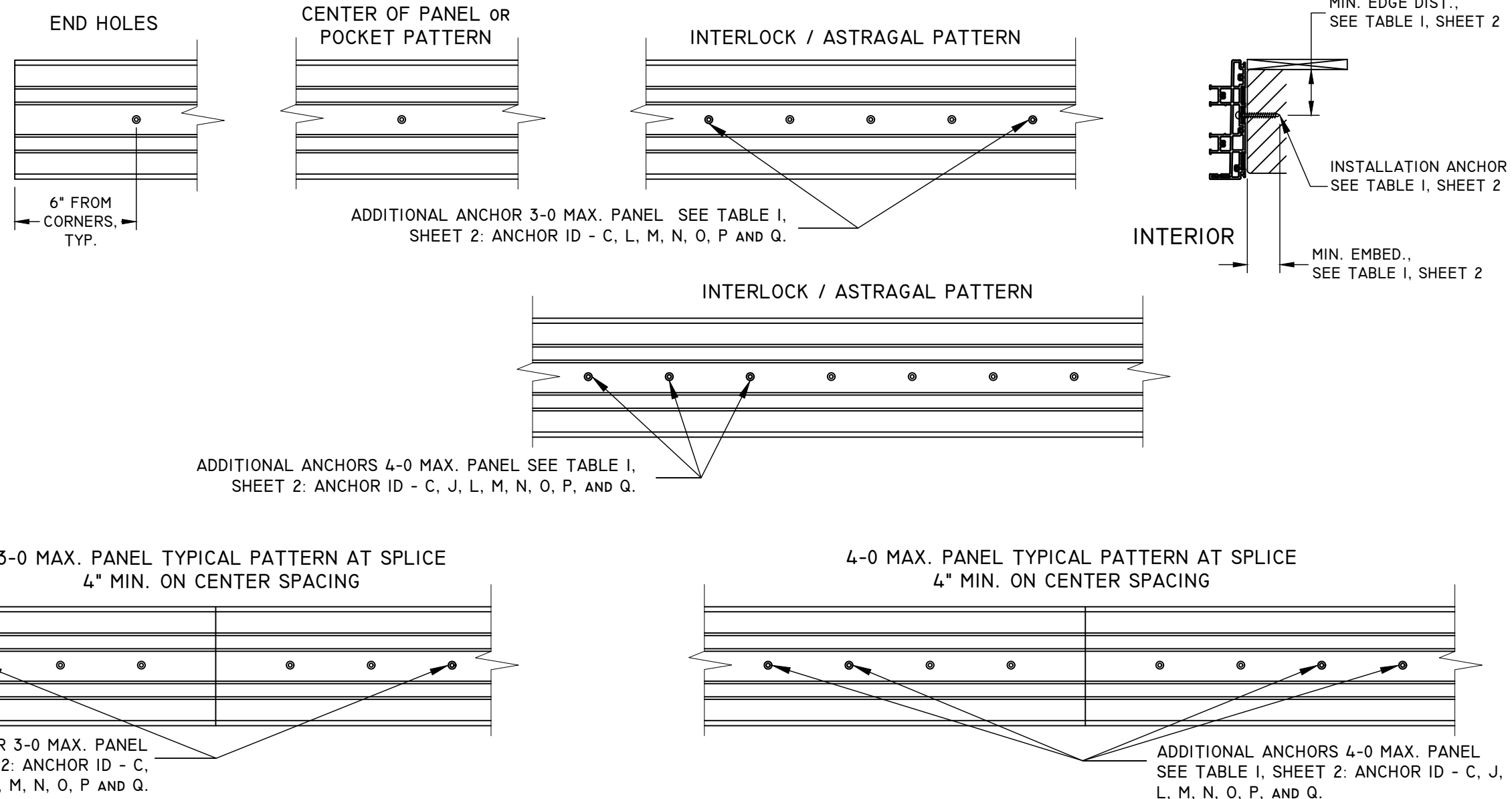

NOTES:

1. INSTALLATION HOLES ARE FABRICATED BY MANUFACTURER.
2. SEE TABLE I, SHEET 2 FOR FASTENER MINIMUM EDGE DISTANCE, EMBEDMENT AND ON CENTER SPACING.
3. IX WOOD BUCK BY OTHERS IS OPTIONAL FOR MASONRY APPLICATIONS.
4. SILL NAIL FIN IS OPTIONAL.
5. 1/4" MAX. SHIM STACK.
6. SPLICE DETAILS, SEE SHEET 25.
7. FILL ALL PRE-DRILLED INSTALLATION HOLES WITH EXTERIOR GRADE SEALANT PRIOR TO INSERTING SCREWS AND APPLY SEALANT OVER THE HEAD OF SCREWS ONCE PROPERLY SEATED.

TITLE: PERSPECTIVE MULTI-SLIDE PATIO DOOR IMPACT ANCHOR LAYOUT	DATE			
	BY			
NO.	REVISION DESCRIPTION			
DATE: 08/25/23	DWN BY: LMH	CHK BY: SAS	SCALE: NTS	



12/12/2023
LUCAS A. TURNER, P.E.
FL PE # 58201
TURNER ENGINEERING & CONSULTING, INC.
(COA # 29779)
2428 OLD NATCHEZ TRACE
TRAIL, CAMDEN, TN 38320
PH. 941-380-1574

FL#: 41161
DWG #: PGW342
SHEET: 10 OF 26

2 TRACK ANCHOR LAYOUT DETAILS BOX FRAME - JAMBS

JAMB - DP60 (+60/-65) IMPACT

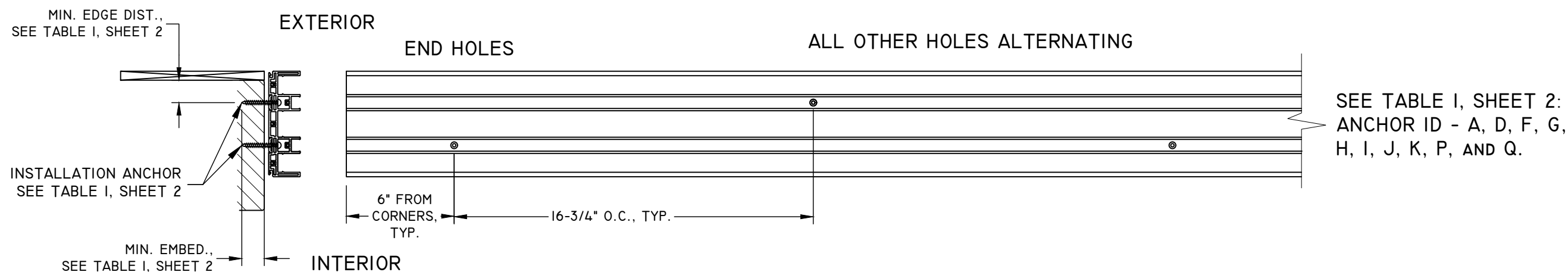

SEE TABLE I, SHEET 2:
ANCHOR ID - A, D, F, G,
H, I, J, K, P, AND Q.

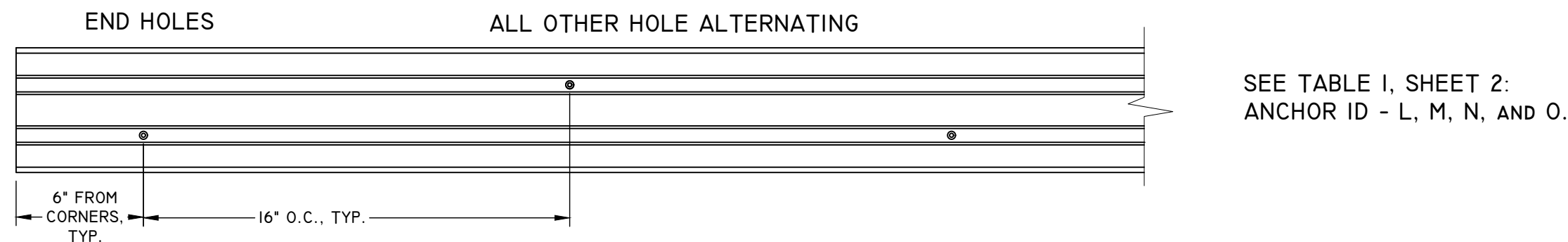

SEE TABLE I, SHEET 2:
ANCHOR ID - L, M, N, AND O.

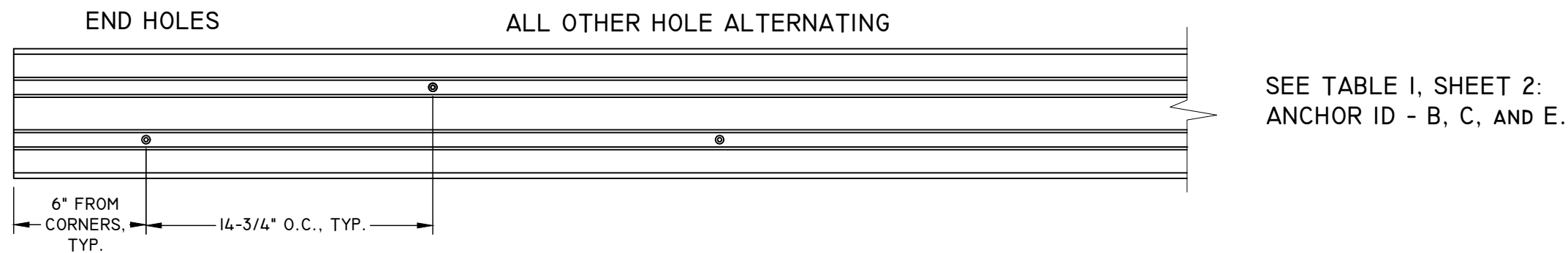

SEE TABLE I, SHEET 2:
ANCHOR ID - B, C, AND E.

NOTES:

1. INSTALLATION HOLES ARE FABRICATED BY MANUFACTURER.
2. SEE TABLE I, SHEET 2 FOR FASTENER MINIMUM EDGE DISTANCE, EMBEDMENT AND ON CENTER SPACING.
3. IX WOOD BUCK BY OTHERS IS OPTIONAL FOR MASONRY APPLICATIONS.
4. 1/4" MAX. SHIM STACK.
5. FILL LEFT & RIGHT PRE-DRILLED JAMB INSTALLATION HOLES - 6" FROM CORNER OF SILL ONLY, WITH EXTERIOR GRADE SEALANT PRIOR TO INSERTING SCREWS AND APPLY SEALANT OVER THE HEAD OF THE SCREWS ONCE PROPERLY SEATED.

TITLE: PERSPECTIVE MULTI-SLIDE PATIO DOOR IMPACT ANCHOR LAYOUT	DATE			
	BY			
	REVISION DESCRIPTION			
	NO.			

DATE: 08/25/23	DWN BY: LMH	CHK BY: SAS	SCALE: NTS
-------------------	----------------	----------------	---------------

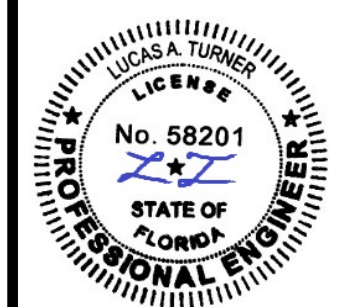

12/12/2023
LUCAS A. TURNER, P.E.
FL PE # 58201
TURNER ENGINEERING &
CONSULTING, INC.
(COA # 29779)
2428 OLD NATCHEZ TRACE
TRAIL, CAMDEN, TN 38320
PH. 941-380-1574

FL#:	41161
DWG #:	PGW342
SHEET:	11 OF 26

3 TRACK ANCHOR LAYOUT DETAILS WITH NAIL FIN - HEAD

HEAD - DP60 (+60/-65) IMPACT

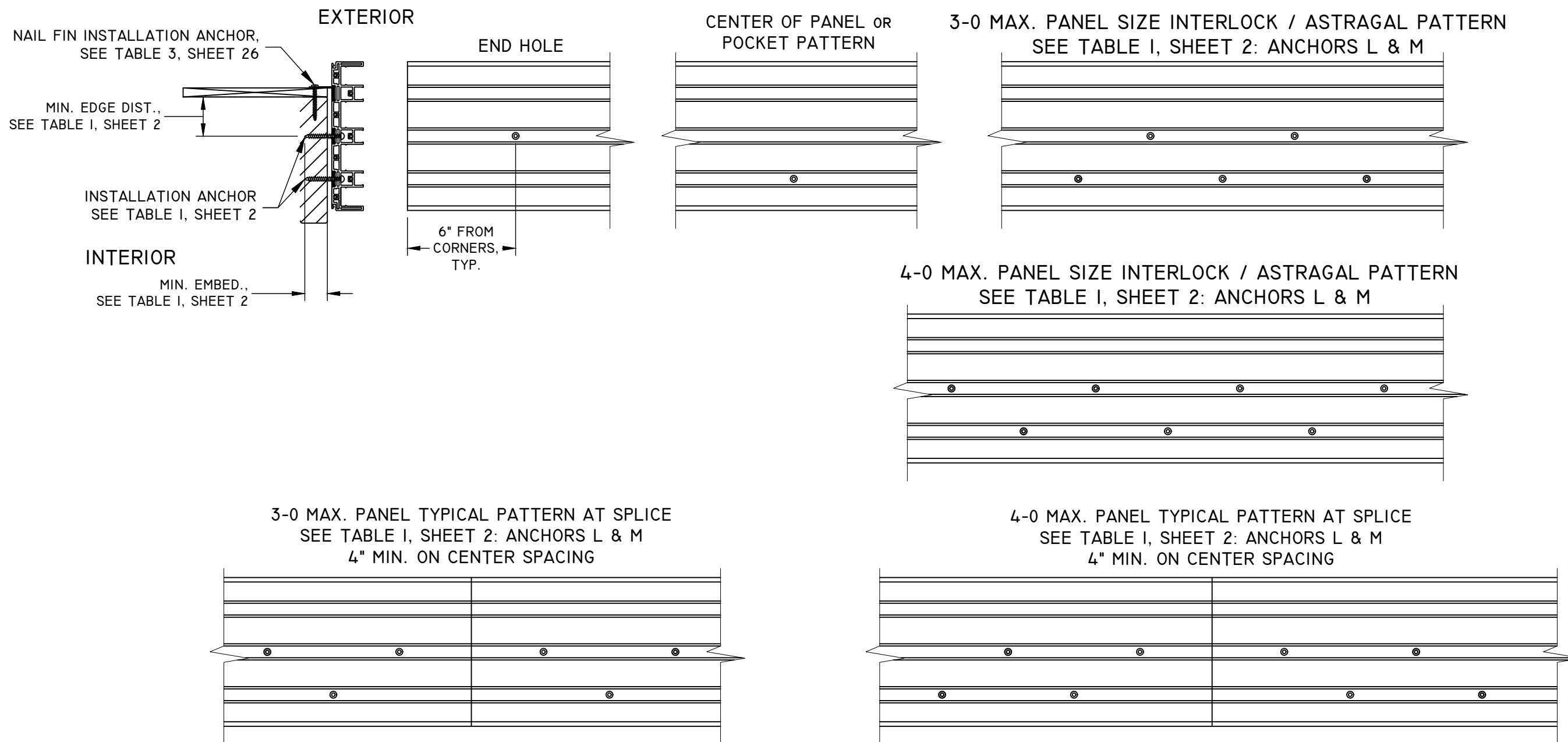

NOTES:

1. UNIT MUST BE INSTALLED WITH ANCHORS THROUGH FRAME AND THROUGH NAIL FIN SIMULTANEOUSLY.
2. 2X MIN. WOOD OR METAL INSTALLATIONS ONLY. WOOD OR METAL MAY BE INSTALLED BY OTHERS OVER CONCRETE/MASONRY NOT SHOWN.
3. SEE SHEET 26 FOR SUPPLEMENTAL INSTALLATION PATTERN THROUGH NAIL FIN, DETAIL A.
4. FRAME INSTALLATION HOLES ARE FABRICATED BY MANUFACTURER.
5. SEE TABLE 1, SHEET 2 FOR FASTENER MINIMUM EDGE DISTANCE, EMBEDMENT AND ON CENTER SPACING.
6. 1/4" MAX. SHIM STACK.
7. SPLICE DETAIL, SEE SHEET 25.

TITLE: PERSPECTIVE MULTI-SLIDE PATIO DOOR IMPACT ANCHOR LAYOUT	DATE			
	BY			
NO.	REVISION DESCRIPTION			

DATE: 08/25/23	DWN BY: LMH	CHK BY: SAS	SCALE: NTS
----------------	-------------	-------------	------------

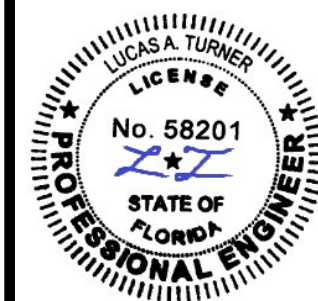

12/12/2023
LUCAS A. TURNER, P.E.
FL PE # 58201
TURNER ENGINEERING & CONSULTING, INC.
(COA # 29779)
2428 OLD NATCHEZ TRACE
TRAIL, CAMDEN, TN 38320
PH. 941-380-1574

FL#: 41161

DWG #: PGW342

SHEET: 12 OF 26

3 TRACK ANCHOR LAYOUT DETAILS WITH NAIL FIN - SILL

SILL - DP60 (+60/-65) IMPACT

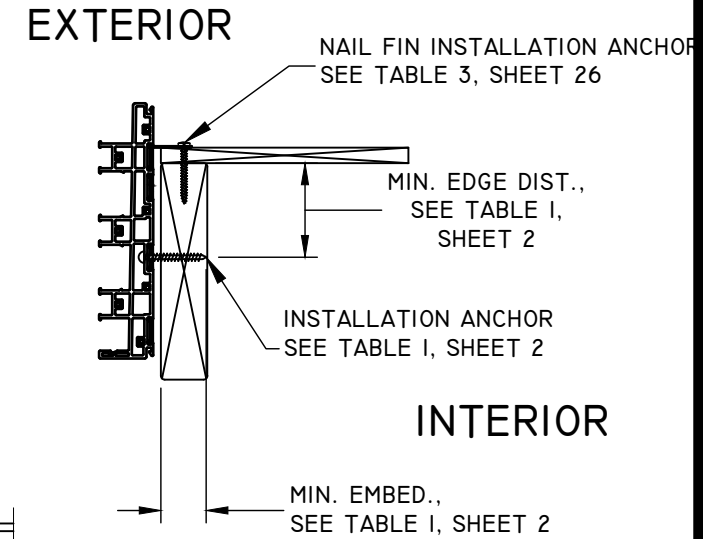
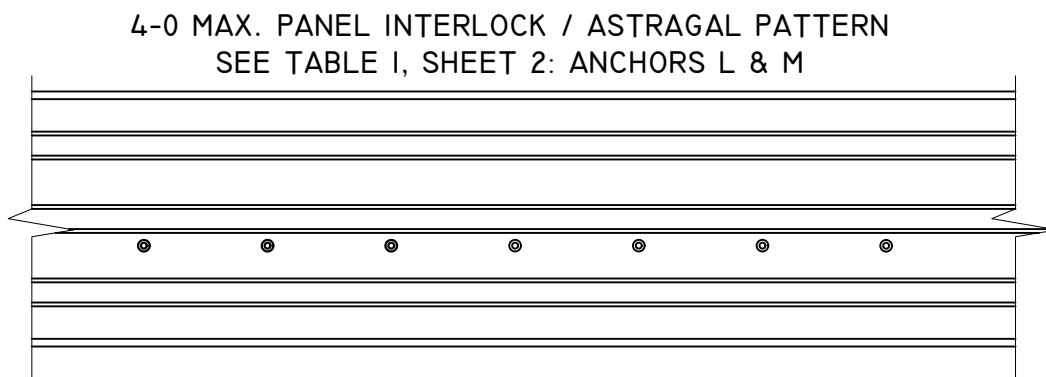
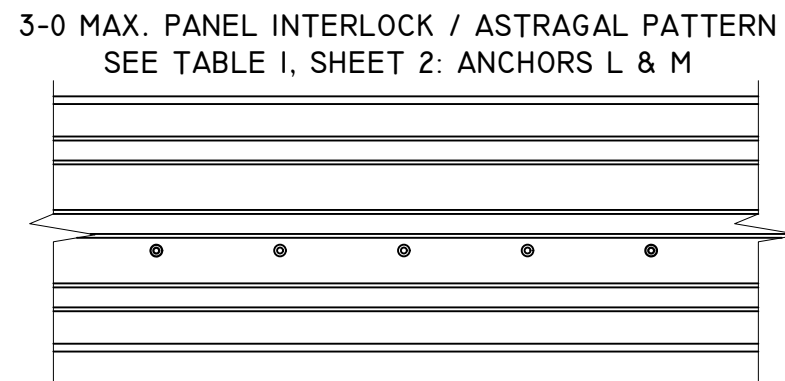
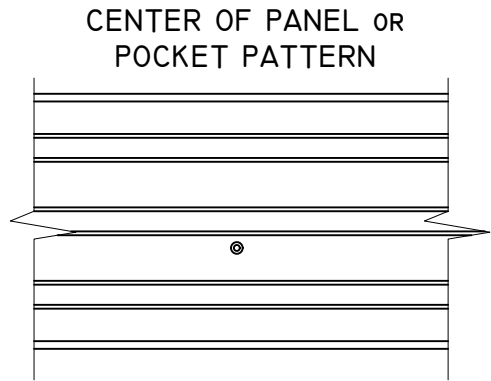
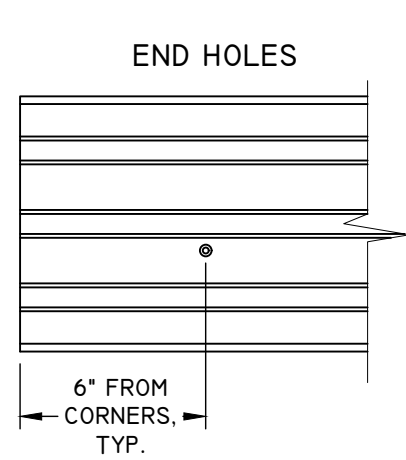

3-0 MAX. PANEL TYPICAL PATTERN AT SPLICE
SEE TABLE I, SHEET 2: ANCHORS L & M
4" MIN. ON CENTER SPACING

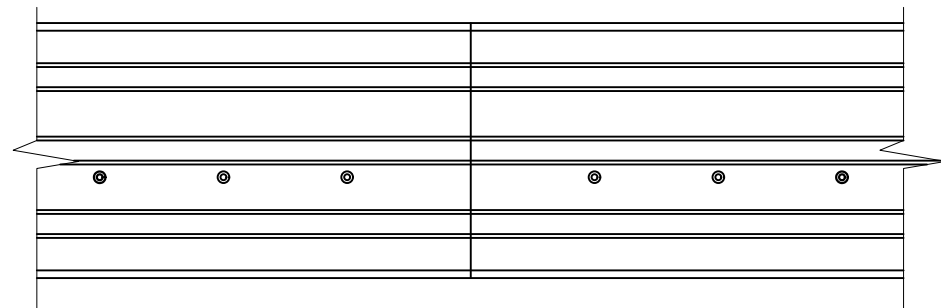

4-0 MAX. PANEL TYPICAL PATTERN AT SPLICE
SEE TABLE I, SHEET 2: ANCHORS L & M
4" MIN. ON CENTER SPACING

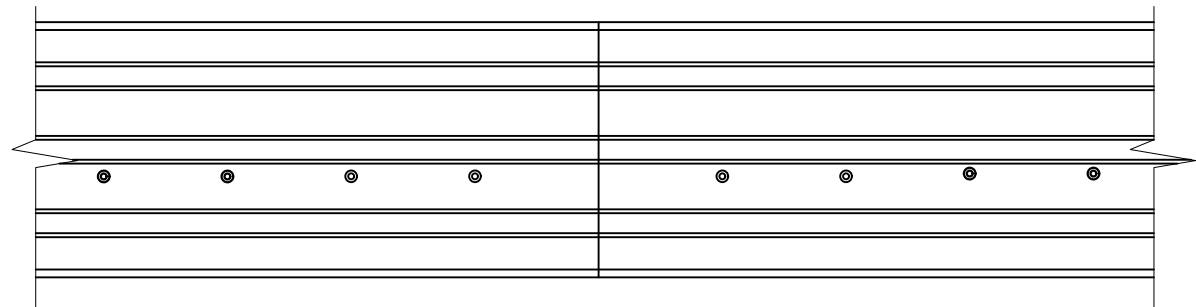

NOTES:

1. UNIT MUST BE INSTALLED WITH ANCHORS THROUGH FRAME AND THROUGH NAIL FIN SIMULTANEOUSLY.
2. 2X MIN. WOOD OR METAL INSTALLATIONS ONLY. WOOD OR METAL MAY BE INSTALLED BY OTHERS OVER CONCRETE/MASONRY, NOT SHOWN.
3. SEE SHEET 26 FOR SUPPLEMENTAL INSTALLATION PATTERN THROUGH NAIL FIN, DETAIL B.
4. FRAME INSTALLATION HOLES ARE FABRICATED BY MANUFACTURER.
5. SEE TABLE I, SHEET 2 FOR FASTENER MINIMUM EDGE DISTANCE, EMBEDMENT AND ON CENTER SPACING.
6. 1/4" MAX. SHIM STACK.
7. SPLICE DETAIL, SEE SHEET 25.
8. FILL ALL PRE-DRILLED INSTALLATION HOLES WITH EXTERIOR GRADE SEALANT PRIOR TO INSERTING SCREWS AND APPLY SEALANT OVER THE HEAD OF SCREWS ONCE PROPERLY SEATED.

TITLE: PERSPECTIVE MULTI-SLIDE PATIO DOOR IMPACT ANCHOR LAYOUT	DATE			
	BY			
NO.	REVISION DESCRIPTION			
DATE: 08/25/23	DWN BY: LMH	CHK BY: SAS	SCALE: NTS	

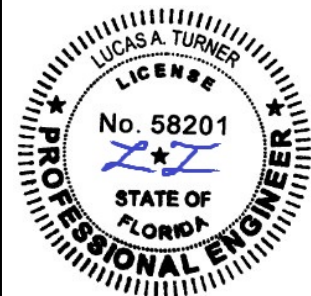

12/12/2023
LUCAS A. TURNER, P.E.
FL PE # 58201
TURNER ENGINEERING & CONSULTING, INC.
(COA # 29779)
2428 OLD NATCHEZ TRACE
TRAIL, CAMDEN, TN 38320
PH. 941-380-1574

FL#:	41161
DWG #:	PGW342
SHEET:	13 OF 26

3 TRACK ANCHOR LAYOUT DETAILS WITH NAIL FIN - JAMBS

JAMB - DP60 (+60/-65) IMPACT

SEE TABLE I, SHEET 2:
ANCHOR ID - L & M

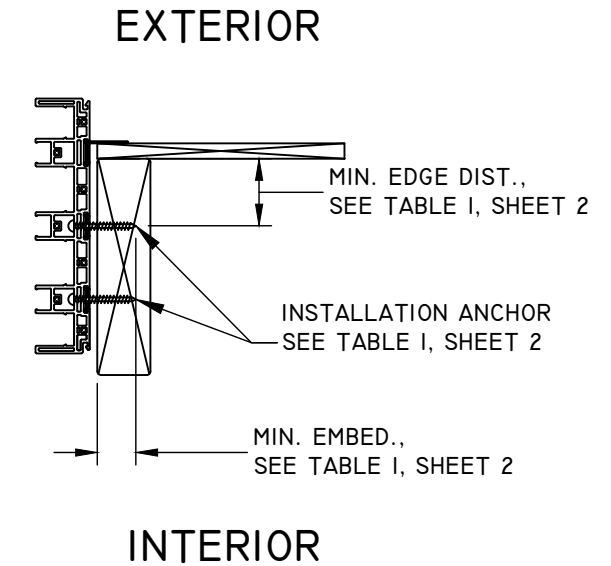
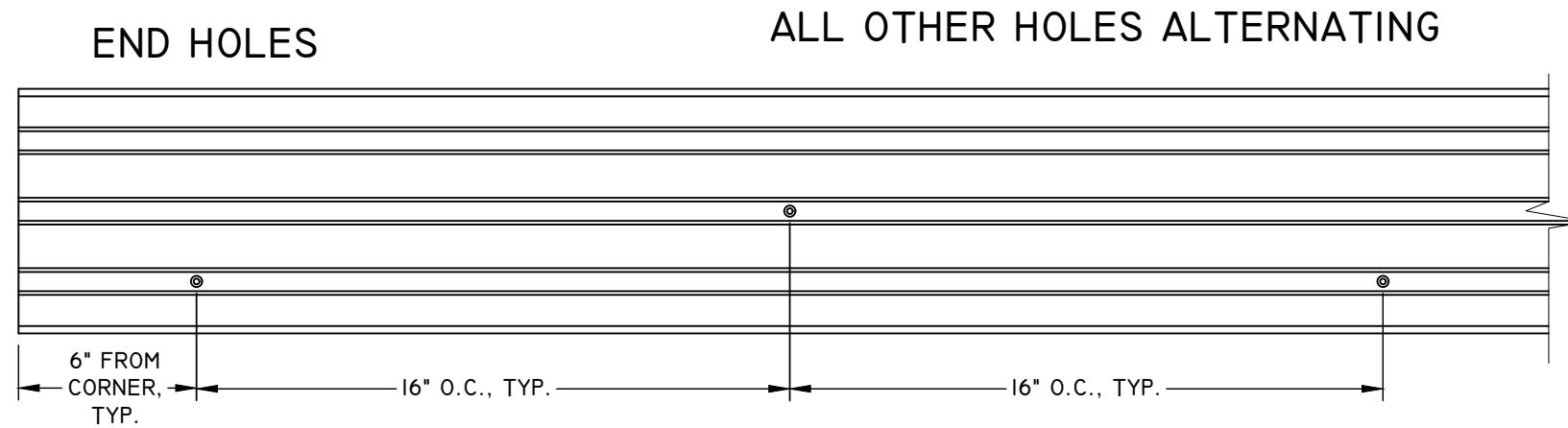

TITLE: PERSPECTIVE MULTI-SLIDE PATIO DOOR IMPACT ANCHOR LAYOUT	DATE			
	BY			
NO.	REVISION DESCRIPTION			
DATE: 08/25/23	DWN BY: LMH	CHK BY: SAS	SCALE: NTS	

NOTES:

1. INSTALLATION HOLES ARE FABRICATED BY MANUFACTURER.
2. SEE TABLE I, SHEET 2 FOR FASTENER MINIMUM EDGE DISTANCE, EMBEDMENT AND ON CENTER SPACING.
2. 2X MIN. WOOD OR METAL INSTALLATIONS ONLY. WOOD OR METAL MAY BE INSTALLED BY OTHERS OVER CONCRETE/MASONRY NOT SHOWN.
3. 1/4" MAX. SHIM STACK.
4. FILL LEFT & RIGHT PRE-DRILLED JAMB INSTALLATION HOLES - 6" FROM CORNER OF SILL ONLY, WITH EXTERIOR GRADE SEALANT PRIOR TO INSERTING SCREWS AND APPLY SEALANT OVER THE HEAD OF THE SCREWS ONCE PROPERLY SEATED.



12/12/2023
LUCAS A. TURNER, P.E.
FL PE # 58201
TURNER ENGINEERING &
CONSULTING, INC.
(COA # 29779)
2428 OLD NATCHEZ TRACE
TRAIL, CAMDEN, TN 38320
PH. 941-380-1574

FL#: **41161**
DWG #: **PGW342**
SHEET: **14 OF 26**

3 TRACK ANCHOR LAYOUT DETAILS BOX FRAME - HEAD

HEAD - DP60 (+60/-65) IMPACT

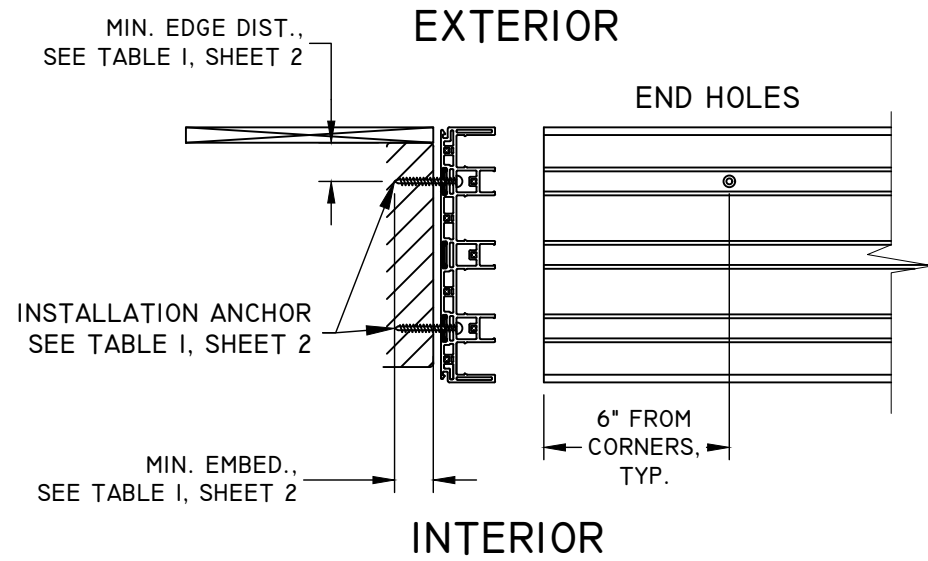

CENTER OF PANEL OR POCKET PATTERN

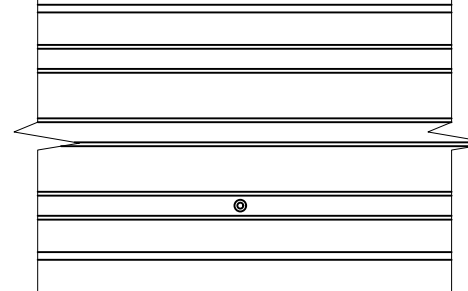

INTERLOCK / ASTRAGAL PATTERN

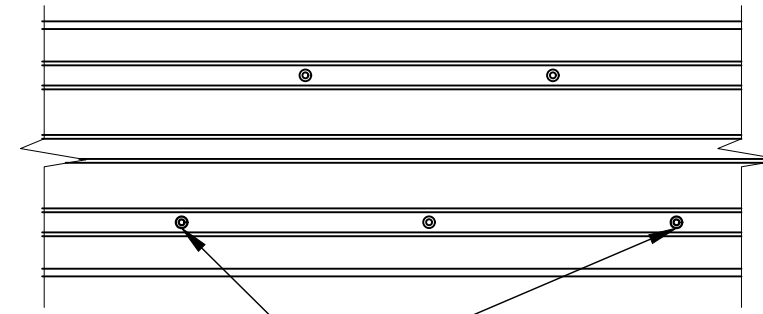

ADDITIONAL ANCHOR 3-0 MAX. PANEL SEE TABLE I, SHEET 2:
ANCHOR ID - C, L, M, N, O, P AND Q.

INTERLOCK / ASTRAGAL PATTERN

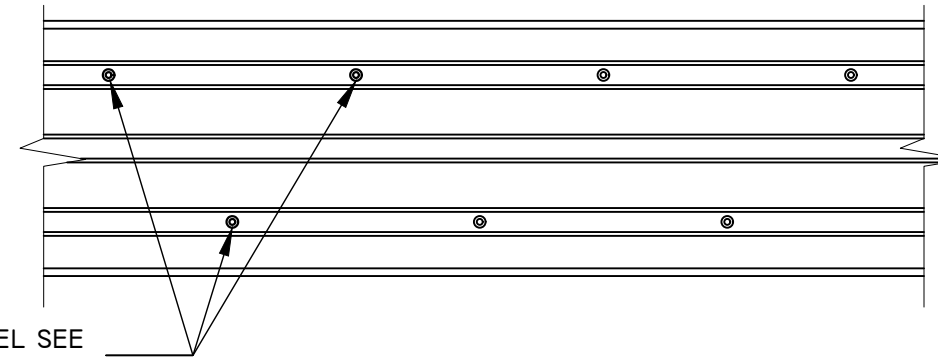

ADDITIONAL ANCHORS 4-0 MAX. PANEL SEE
TABLE I, SHEET 2: ANCHOR ID - C, J, L, M, N, O, P, AND Q.

3-0 MAX. PANEL TYPICAL PATTERN AT SPLICE
4" MIN. ON CENTER SPACING

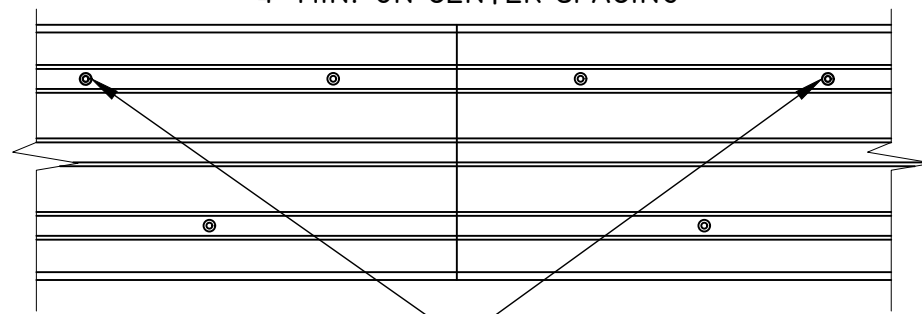

ADDITIONAL ANCHOR 3-0 MAX. PANEL
SEE TABLE I, SHEET 2: ANCHOR ID - C,
L, M, N, O, P AND Q

4-0 MAX. PANEL TYPICAL PATTERN AT SPLICE
4" MIN. ON CENTER SPACING

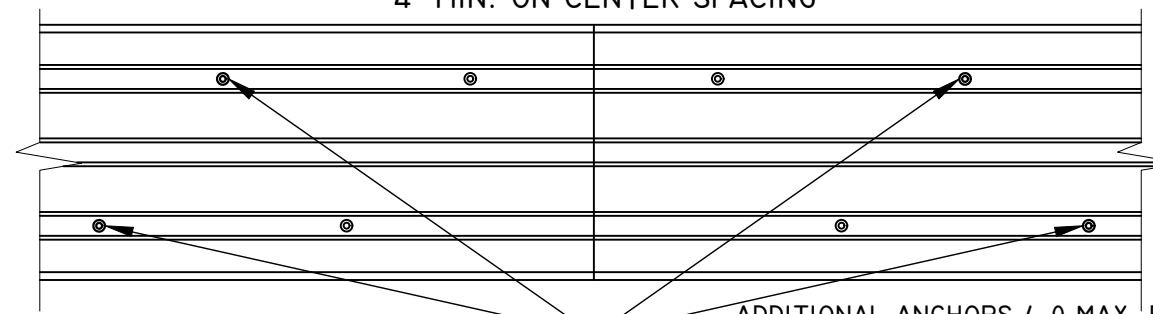

ADDITIONAL ANCHORS 4-0 MAX. PANEL
SEE TABLE I, SHEET 2: ANCHOR ID - C,
J, L, M, N, O, P, AND Q.

NOTES:

1. INSTALLATION HOLES ARE FABRICATED BY MANUFACTURER.
2. SEE TABLE I, SHEET 2 FOR FASTENER MINIMUM EDGE DISTANCE, EMBEDMENT AND ON CENTER SPACING.
3. IX WOOD BUCK BY OTHERS IS OPTIONAL FOR MASONRY APPLICATIONS.
4. 1/4" MAX. SHIM STACK.
5. SPLICE DETAILS, SEE SHEET 25.

TITLE: PERSPECTIVE MULTI-SLIDE PATIO DOOR IMPACT ANCHOR LAYOUT	DATE			
	BY			
	REVISION DESCRIPTION			
NO.				

DATE: 08/25/23	DWN BY: LMH	CHK BY: SAS	SCALE: NTS
----------------	-------------	-------------	------------



12/12/2023
LUCAS A. TURNER, P.E.
FL PE # 58201
TURNER ENGINEERING &
CONSULTING, INC.
(COA # 29779)
2428 OLD NATCHEZ TRACE
TRAIL, CAMDEN, TN 38320
PH. 941-380-1574

FL#:	41161
DWG #:	PGW342
SHEET:	15 OF 26

3 TRACK ANCHOR LAYOUT DETAILS BOX FRAME - SILL

SILL - DP60 (+60/-65) IMPACT

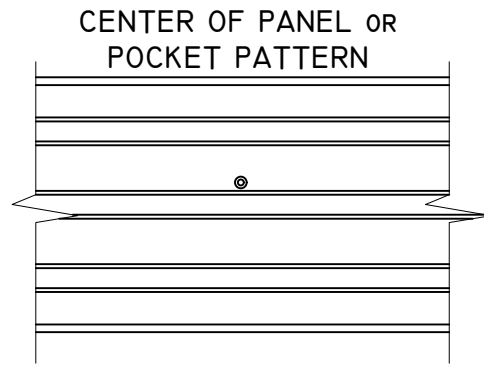
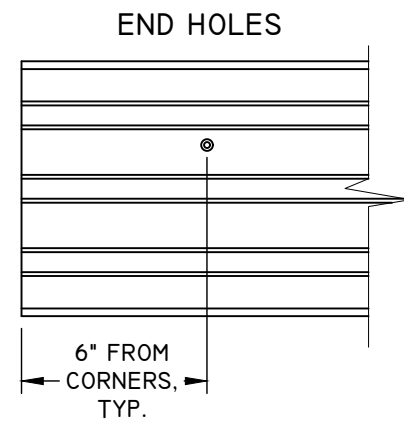

ADDITIONAL ANCHOR 3-0 MAX. PANEL SEE TABLE I, SHEET 2: ANCHOR ID - C, L, M, N, O, P AND Q.

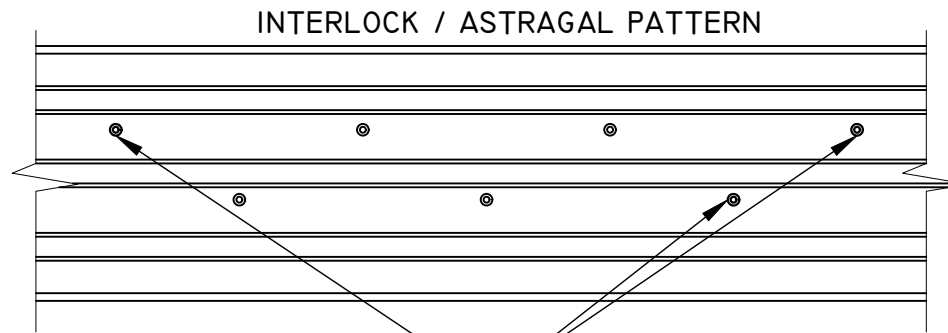
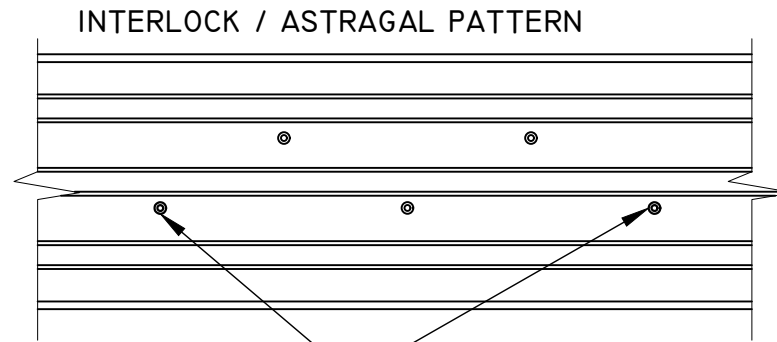

ADDITIONAL ANCHORS 4-0 MAX. PANEL SEE TABLE I, SHEET 2: ANCHOR ID - C, J, L, M, N, O, P, AND Q.

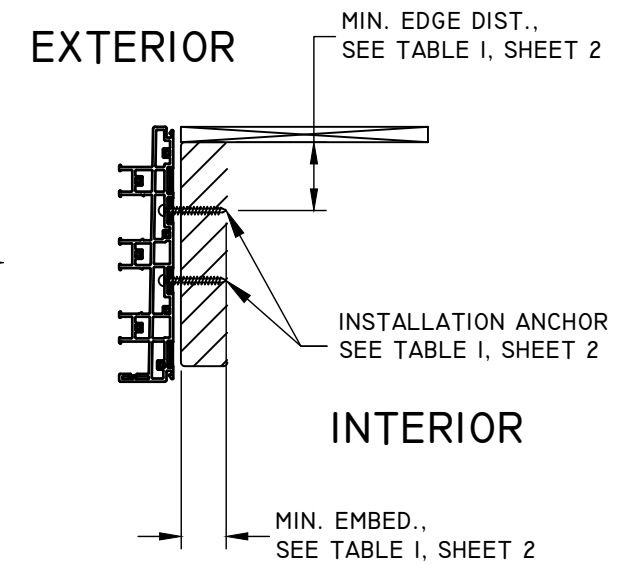

3-0 MAX. PANEL TYPICAL PATTERN AT SPLICE
4" MIN. ON CENTER SPACING

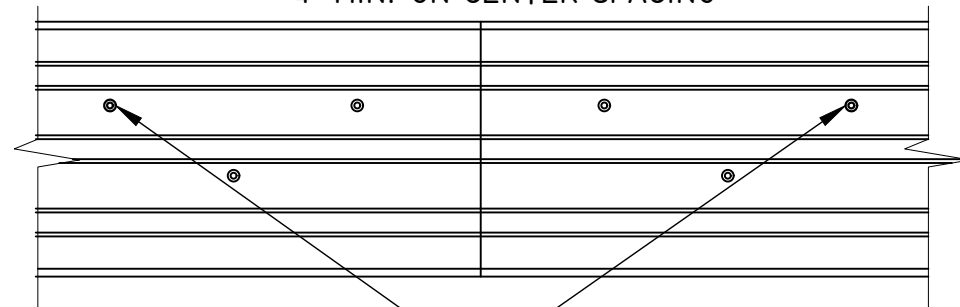

ADDITIONAL ANCHOR 3-0 MAX. PANEL SEE TABLE I, SHEET 2: ANCHOR ID - C, L, M, N, O, P AND Q.

4-0 MAX. PANEL TYPICAL PATTERN AT SPLICE
4" MIN. ON CENTER SPACING

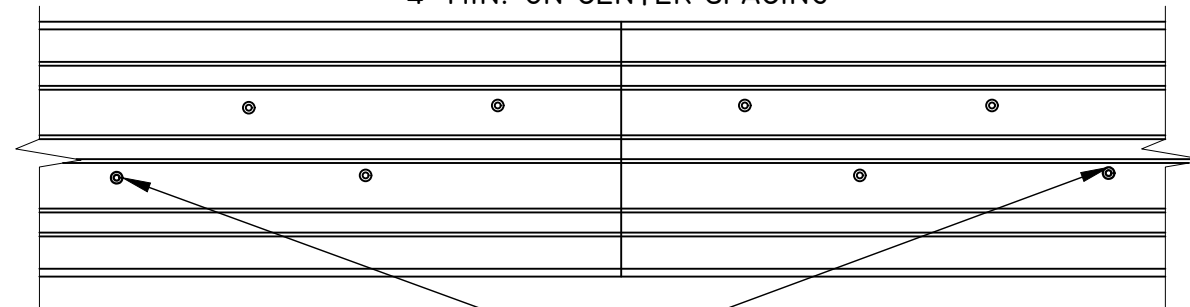

ADDITIONAL ANCHORS 4-0 MAX. PANEL SEE TABLE I, SHEET 2: ANCHOR ID - C, J, L, M, N, O, P, AND Q.

NOTES:

1. INSTALLATION HOLES ARE FABRICATED BY MANUFACTURER.
2. SEE TABLE I, SHEET 2 FOR FASTENER MINIMUM EDGE DISTANCE, EMBEDMENT AND ON CENTER SPACING.
3. IX WOOD BUCK BY OTHERS IS OPTIONAL FOR MASONRY APPLICATIONS.
4. 1/4" MAX. SHIM STACK.
5. SPLICE DETAILS, SEE SHEET 25.
6. FILL ALL PRE-DRILLED INSTALLATION HOLES WITH EXTERIOR GRADE SEALANT PRIOR TO INSERTING SCREWS AND APPLY SEALANT OVER THE HEAD OF SCREWS ONCE PROPERLY SEATED.

TITLE: PERSPECTIVE MULTI-SLIDE PATIO DOOR IMPACT ANCHOR LAYOUT	DATE			
	BY			
NO.	REVISION DESCRIPTION			
DATE: 08/25/23	DWN BY: LMH	CHK BY: SAS	SCALE: NTS	

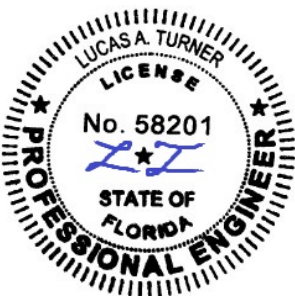

12/12/2023
LUCAS A. TURNER, P.E.
FL PE # 58201
TURNER ENGINEERING & CONSULTING, INC.
(COA # 29779)
2428 OLD NATCHEZ TRACE
TRAIL, CAMDEN, TN 38320
PH. 941-380-1574

FL#:	41161
DWG #:	PGW342
SHEET:	16 OF 26

3 TRACK ANCHOR LAYOUT DETAILS BOX FRAME - JAMBS

JAMB - DP60 (+60/-65) IMPACT

SEE TABLE I, SHEET 2:
ANCHOR ID - A, D, F, G,
H, I, J, K, P, AND Q.

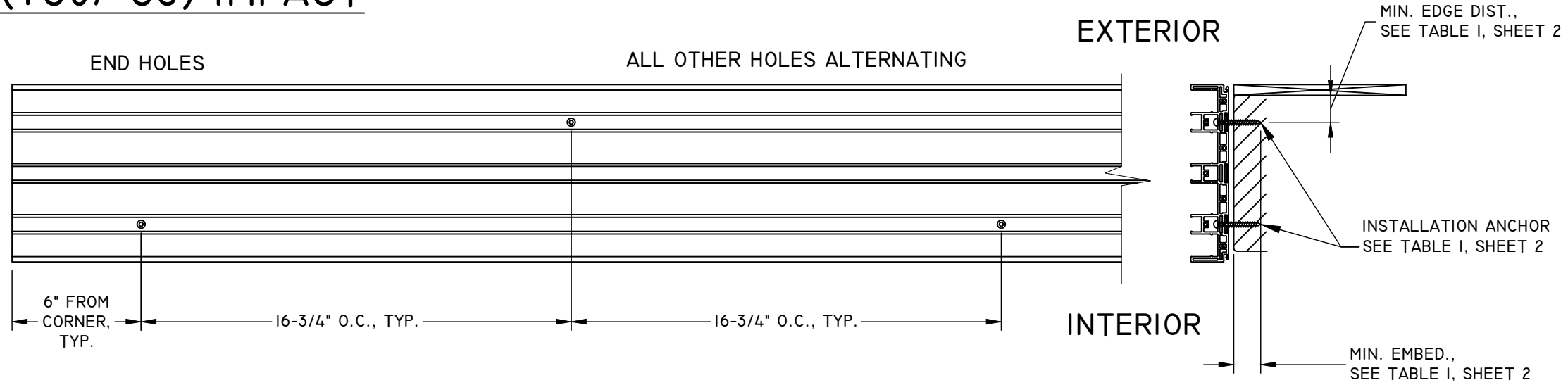

SEE TABLE I, SHEET 2:
ANCHOR ID - L, M, N, AND O.

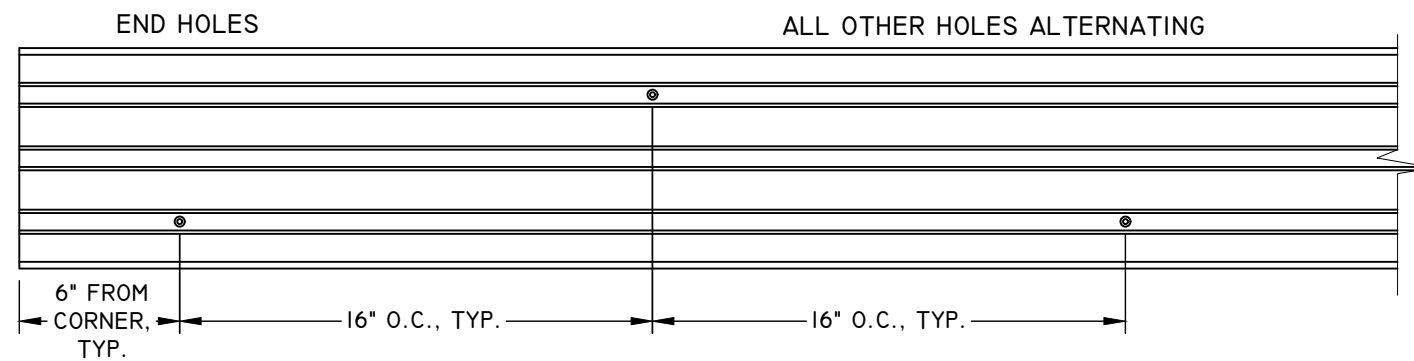

SEE TABLE I, SHEET 2:
ANCHOR ID - B, C, AND E.

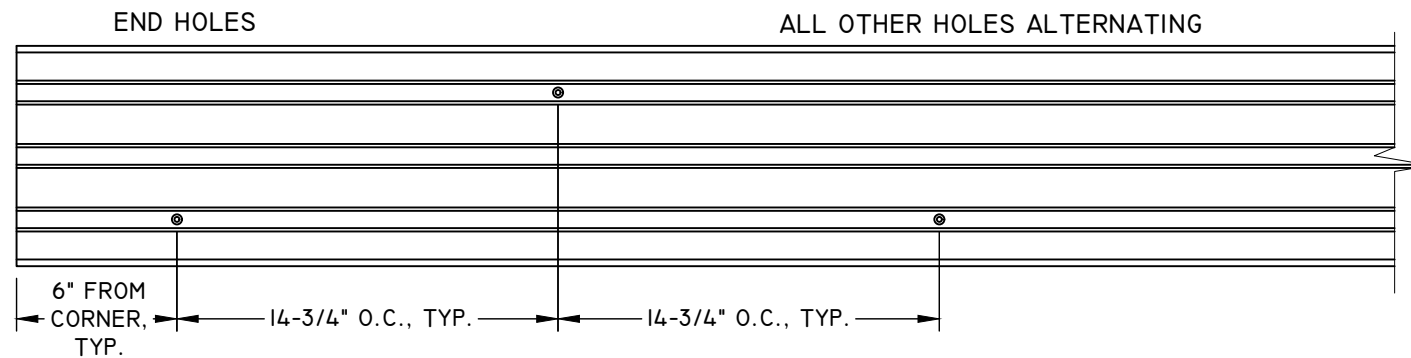

NOTES:

1. INSTALLATION HOLES ARE FABRICATED BY MANUFACTURER.
2. SEE TABLE I, SHEET 2 FOR FASTENER MINIMUM EDGE DISTANCE, EMBEDMENT AND ON CENTER SPACING.
3. IX WOOD BUCK BY OTHERS IS OPTIONAL FOR MASONRY APPLICATIONS.
4. 1/4" MAX. SHIM STACK.
5. FILL LEFT & RIGHT PRE-DRILLED JAMB INSTALLATION HOLES - 6" FROM CORNER OF SILL ONLY, WITH EXTERIOR GRADE SEALANT PRIOR TO INSERTING SCREWS AND APPLY SEALANT OVER THE HEAD OF THE SCREWS ONCE PROPERLY SEATED.

TITLE: PERSPECTIVE MULTI-SLIDE PATIO DOOR IMPACT ANCHOR LAYOUT	DATE			
	BY			
NO.	REVISION DESCRIPTION			
DATE: 08/25/23	DWN BY: LMH	CHK BY: SAS	SCALE: NTS	

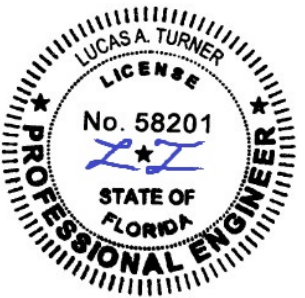

12/12/2023
LUCAS A. TURNER, P.E.
FL PE # 58201
TURNER ENGINEERING &
CONSULTING, INC.
(COA # 29779)
2428 OLD NATCHEZ TRACE
TRAIL, CAMDEN, TN 38320
PH. 941-380-1574

FL#: 41161

DWG #: PGW342

SHEET: 17 OF 26

4 TRACK ANCHOR LAYOUT DETAILS WITH NAIL FIN - HEAD

HEAD - DP60 (+60/-65) IMPACT

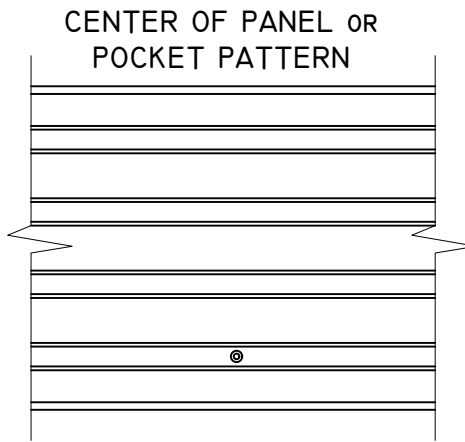
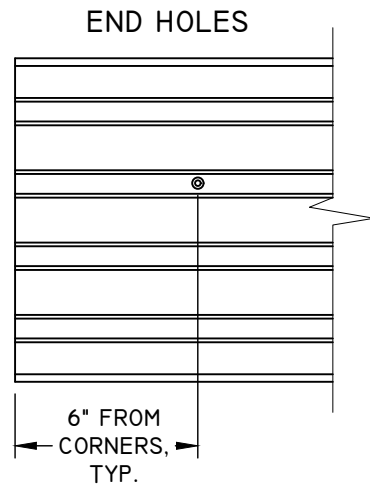
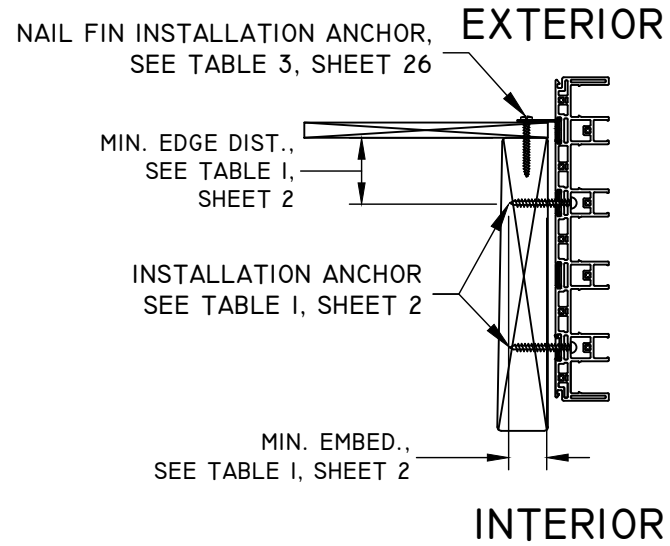

3-0 MAX. PANEL SIZE INTERLOCK / ASTRAGAL PATTERN
SEE TABLE 1, SHEET 2: ANCHORS L & M

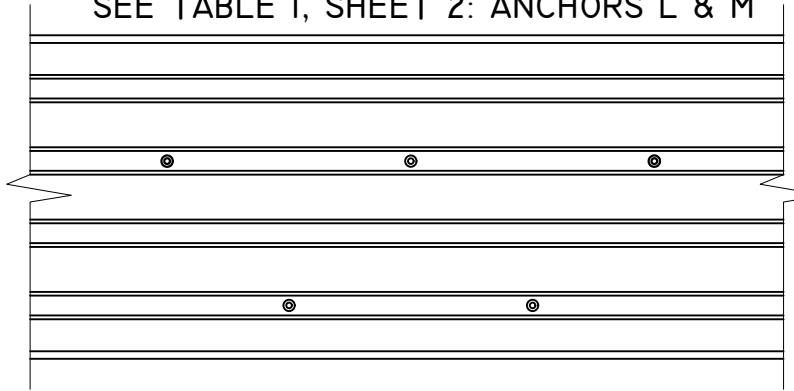

4-0 MAX. PANEL SIZE INTERLOCK / ASTRAGAL PATTERN
SEE TABLE 1, SHEET 2: ANCHORS L & M

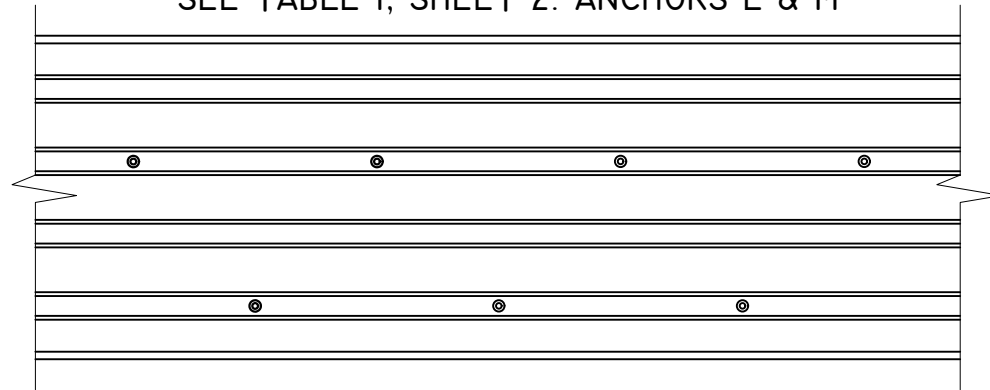

3-0 MAX. PANEL TYPICAL PATTERN AT SPLICE
SEE TABLE 1, SHEET 2: ANCHORS L & M
4" MIN. ON CENTER SPACING

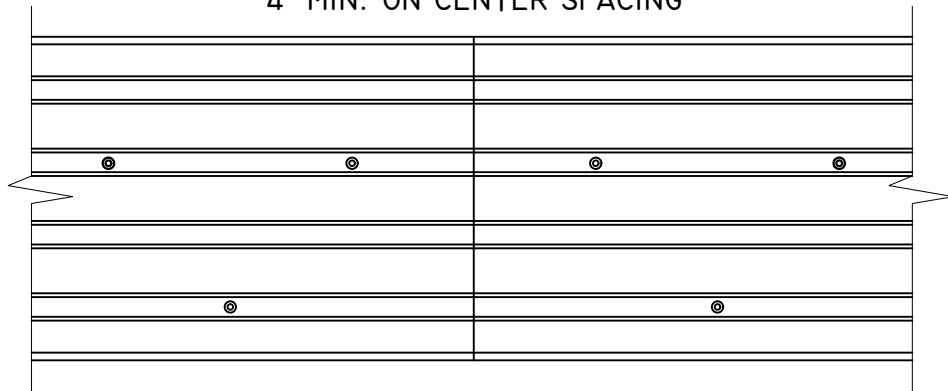

4-0 MAX. PANEL TYPICAL PATTERN AT SPLICE
SEE TABLE 1, SHEET 2: ANCHORS L & M
4" MIN. ON CENTER SPACING

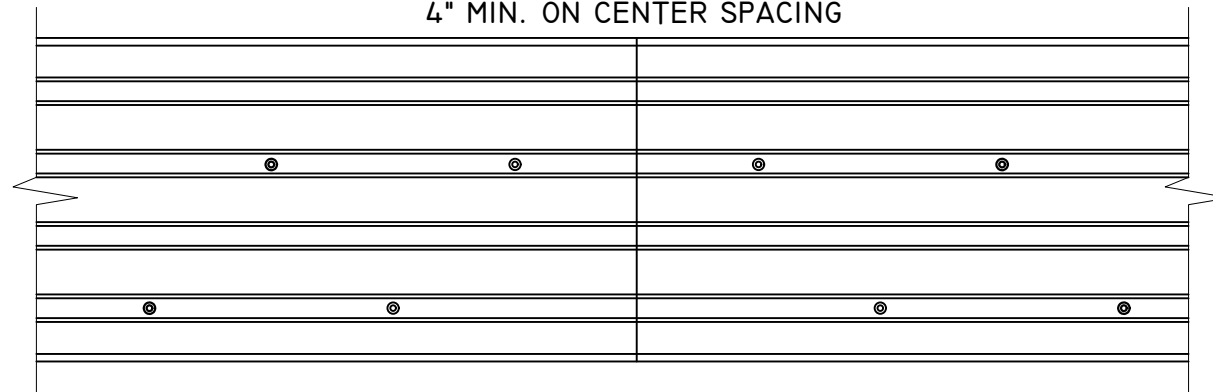

NOTES:

1. UNIT MUST BE INSTALLED WITH ANCHORS THROUGH FRAME AND THROUGH NAIL FIN SIMULTANEOUSLY.
2. 2X MIN. WOOD OR METAL INSTALLATIONS ONLY. WOOD OR METAL MAY BE INSTALLED BY OTHERS OVER CONCRETE/MASONRY NOT SHOWN.
3. SEE SHEET 26 FOR SUPPLEMENTAL INSTALLATION PATTERN THROUGH NAIL FIN, DETAIL A.
4. FRAME INSTALLATION HOLES ARE FABRICATED BY MANUFACTURER.
5. SEE TABLE 1, SHEET 2 FOR FASTENER MINIMUM EDGE DISTANCE, EMBEDMENT AND ON CENTER SPACING.
6. 1/4" MAX. SHIM STACK.
7. SPLICE DETAIL, SEE SHEET 25.

TITLE: PERSPECTIVE MULTI-SLIDE PATIO DOOR IMPACT ANCHOR LAYOUT	DATE				
	BY				
	REVISION DESCRIPTION				
	NO.				
DATE: 08/25/23	DWN BY: LMH	CHK BY: SAS	SCALE: NTS		



12/12/2023
LUCAS A. TURNER, P.E.
FL PE # 58201
TURNER ENGINEERING & CONSULTING, INC.
(COA # 29779)
2428 OLD NATCHEZ TRACE TRAIL, CAMDEN, TN 38320
PH. 941-380-1574

FL#:	41161
DWG #:	PGW342
SHEET:	18 OF 26

4 TRACK ANCHOR LAYOUT DETAILS WITH NAIL FIN - SILL

SILL - DP60 (+60/-65) IMPACT

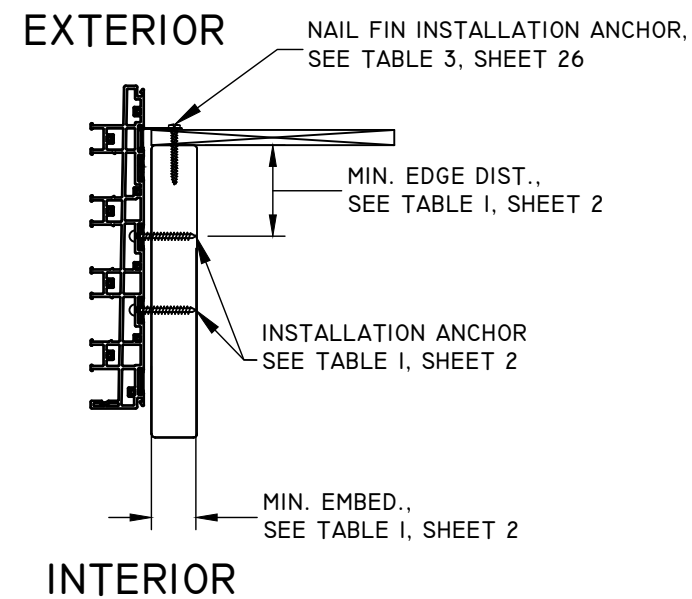
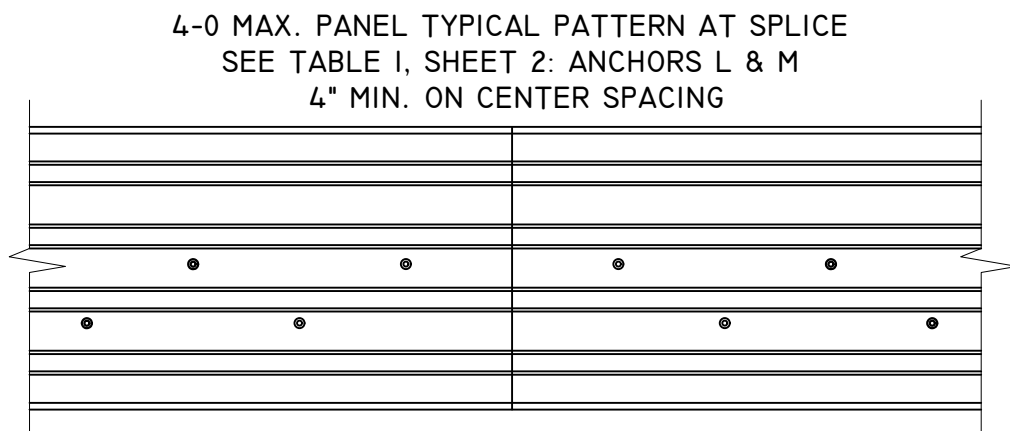
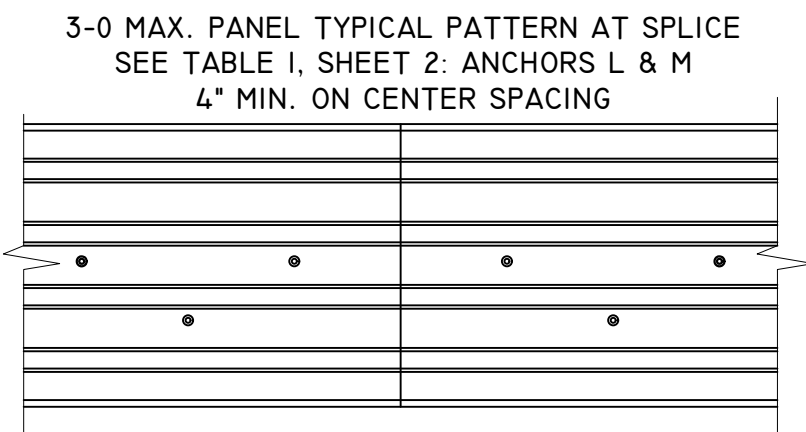
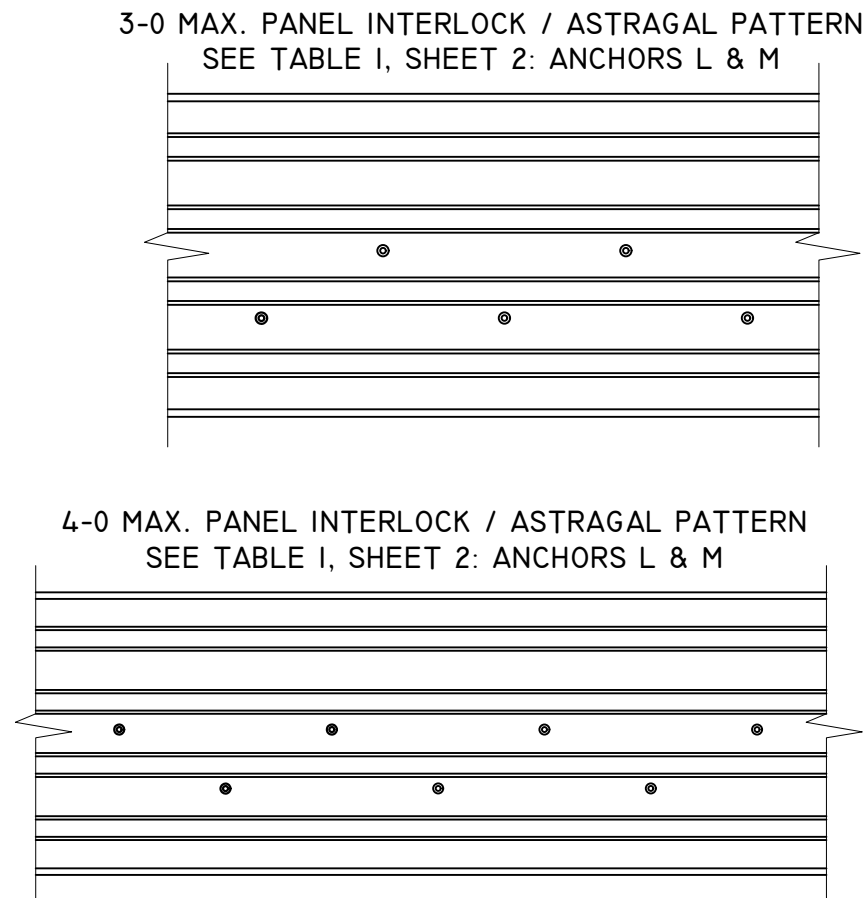
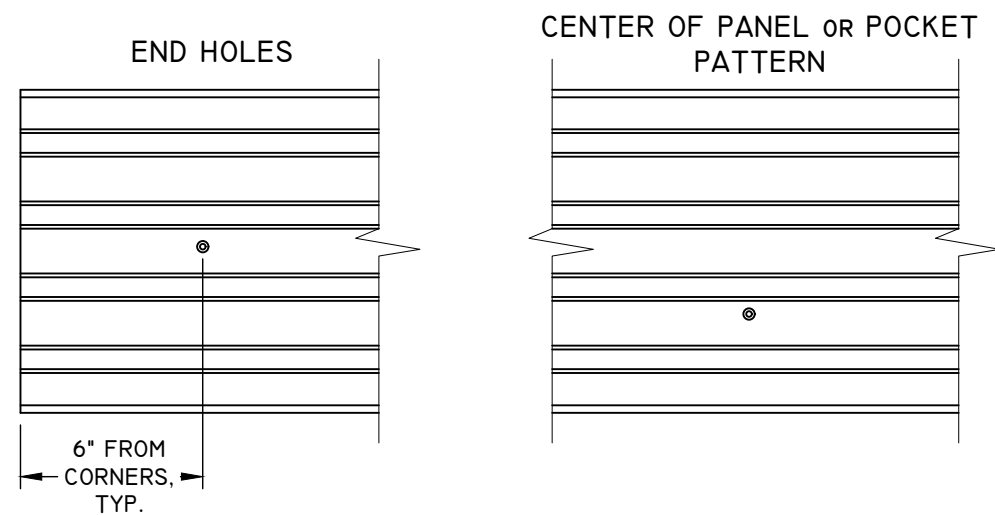

NOTES:

1. UNIT MUST BE INSTALLED WITH ANCHORS THROUGH FRAME AND THROUGH NAIL FIN SIMULTANEOUSLY.
2. 2X MIN. WOOD OR METAL INSTALLATIONS ONLY. WOOD OR METAL MAY BE INSTALLED BY OTHERS OVER CONCRETE/MASONRY, NOT SHOWN.
3. SEE SHEET 26 FOR SUPPLEMENTAL INSTALLATION PATTERN THROUGH NAIL FIN, DETAIL B.
4. FRAME INSTALLATION HOLES ARE FABRICATED BY MANUFACTURER.
5. SEE TABLE I, SHEET 2 FOR FASTENER MINIMUM EDGE DISTANCE, EMBEDMENT AND ON CENTER SPACING.
6. 1/4" MAX. SHIM STACK.
7. SPLICE DETAIL, SEE SHEET 25.
8. FILL ALL PRE-DRILLED INSTALLATION HOLES WITH EXTERIOR GRADE SEALANT PRIOR TO INSERTING SCREWS AND APPLY SEALANT OVER THE HEAD OF SCREWS ONCE PROPERLY SEATED.

NO.	REVISION DESCRIPTION	BY	DATE

DATE:	DWN BY:	CHK BY:	SCALE:
08/25/23	LMH	SAS	NTS

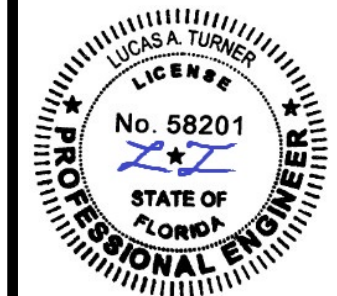

12/12/2023
LUCAS A. TURNER, P.E.
FL PE # 58201
TURNER ENGINEERING &
CONSULTING, INC.
(COA # 29779)
2428 OLD NATCHEZ TRACE
TRAIL, CAMDEN, TN 38320
PH. 941-380-1574

FL#: **41161**

DWG #: **PGW342**

SHEET: **19 OF 26**

4 TRACK ANCHOR LAYOUT DETAILS WITH NAIL FIN - JAMBS

JAMB - DP60 (+60/-65) IMPACT

SEE TABLE I, SHEET 2:
ANCHOR ID - L & M.

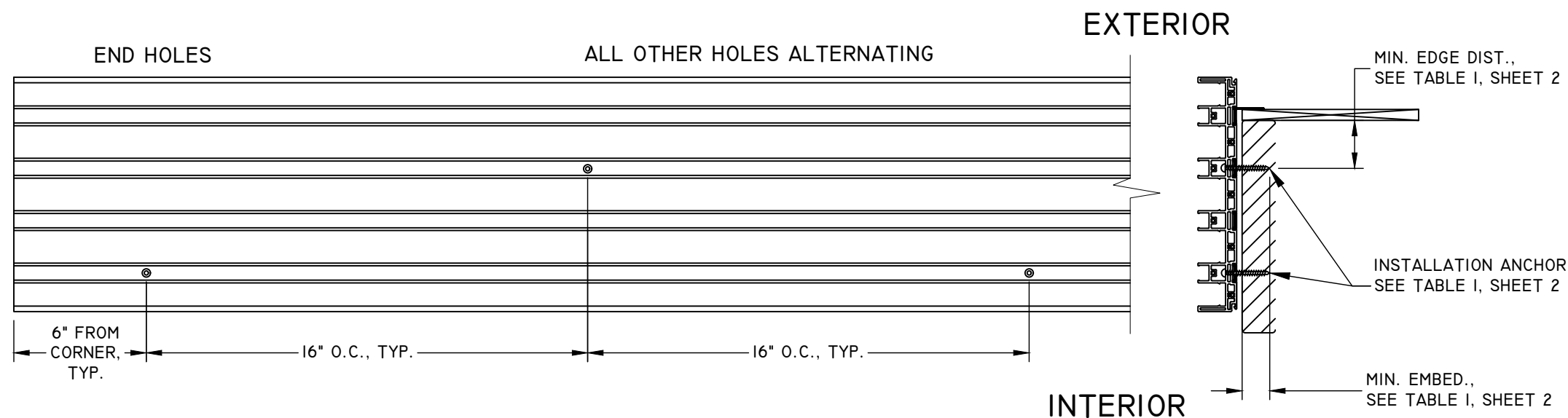

NOTES:

1. INSTALLATION HOLES ARE FABRICATED BY MANUFACTURER.
2. SEE TABLE I, SHEET 2 FOR FASTENER MINIMUM EDGE DISTANCE, EMBEDMENT AND ON CENTER SPACING.
2. 2X MIN. WOOD OR METAL INSTALLATIONS ONLY. WOOD OR METAL MAY BE INSTALLED BY OTHERS OVER CONCRETE/MASONRY NOT SHOWN.
3. 1/4" MAX. SHIM STACK.
4. FILL LEFT & RIGHT PRE-DRILLED JAMB INSTALLATION HOLES - 6" FROM CORNER OF SILL ONLY, WITH EXTERIOR GRADE SEALANT PRIOR TO INSERTING SCREWS AND APPLY SEALANT OVER THE HEAD OF THE SCREWS ONCE PROPERLY SEATED.

TITLE: PERSPECTIVE MULTI-SLIDE PATIO DOOR IMPACT ANCHOR LAYOUT	DATE			
	BY			
	REVISION DESCRIPTION			
	NO.			
DATE:	DWN BY:	CHK BY:	SCALE:	NTS
08/25/23	LMH	SAS		

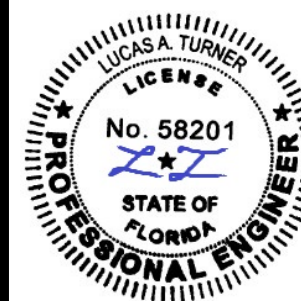

12/12/2023
LUCAS A. TURNER, P.E.
FL PE # 58201
TURNER ENGINEERING &
CONSULTING, INC.
(COA # 29779)
2428 OLD NATCHEZ TRACE
TRAIL, CAMDEN, TN 38320
PH. 941-380-1574

FL#: 41161

DWG #: PGW342

SHEET: 20 OF 26

4 TRACK ANCHOR LAYOUT DETAILS BOX FRAME - HEAD

HEAD - DP60 (+60/-65) IMPACT

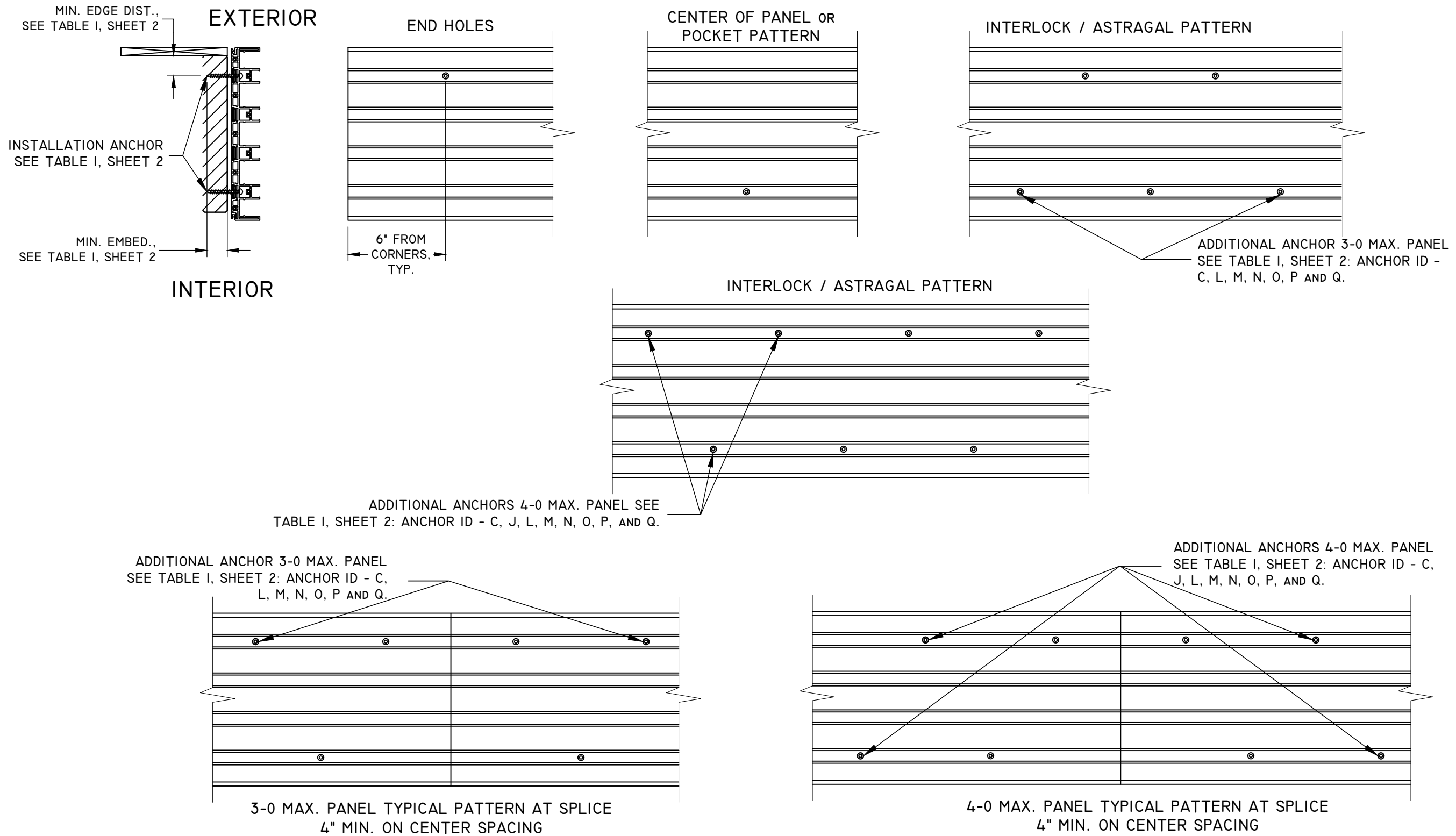

NOTES:

1. INSTALLATION HOLES ARE FABRICATED BY MANUFACTURER.
2. SEE TABLE I, SHEET 2 FOR FASTENER MINIMUM EDGE DISTANCE, EMBEDMENT AND ON CENTER SPACING.
3. 1X WOOD BUCK BY OTHERS IS OPTIONAL FOR MASONRY APPLICATIONS.
4. 1/4" MAX. SHIM STACK.
5. SPLICE DETAILS, SEE SHEET 25.

Ply Gem
WINDOWS & DOORS
Part of the Cornerstone Building Brands Family
433 N. MAIN ST.,
PO BOX 559,
ROCKY MOUNT, VA 24151
PH: 540-484-6348
FX: 540-484-6683

TITLE: PERSPECTIVE MULTI-SLIDE PATIO DOOR IMPACT ANCHOR LAYOUT	DATE			
	BY			
NO.	REVISION DESCRIPTION			
DATE: 08/25/23	DWN BY: LMH	CHK BY: SAS	SCALE: NTS	

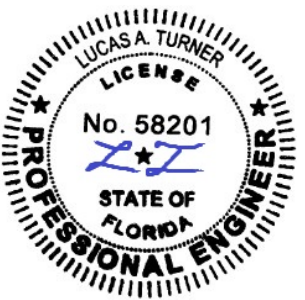

12/12/2023
LUCAS A. TURNER, P.E.
FL PE # 58201
TURNER ENGINEERING & CONSULTING, INC.
(COA # 29779)
2428 OLD NATCHEZ TRACE
TRAIL, CAMDEN, TN 38320
PH. 941-380-1574

FL#:	41161
DWG #:	PGW342
SHEET:	21 OF 26

4 TRACK ANCHOR LAYOUT DETAILS BOX FRAME - SILL

SILL - DP60 (+60/-65) IMPACT

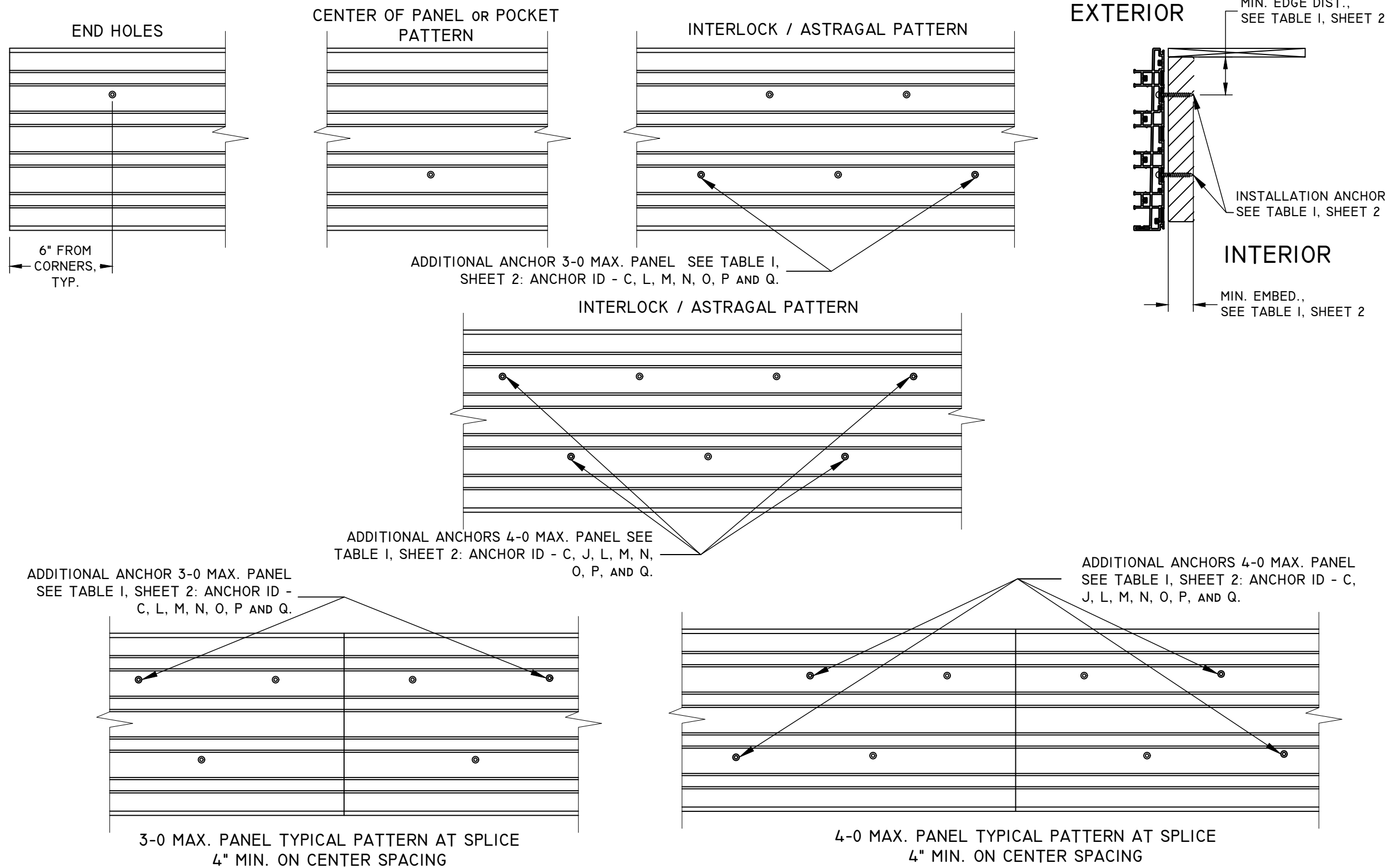

- NOTES:**
1. INSTALLATION HOLES ARE FABRICATED BY MANUFACTURER.
 2. SEE TABLE I, SHEET 2 FOR FASTENER MINIMUM EDGE DISTANCE, EMBEDMENT AND ON CENTER SPACING.
 3. IX WOOD BUCK BY OTHERS IS OPTIONAL FOR MASONRY APPLICATIONS.
 4. 1/4" MAX. SHIM STACK.
 5. SPLICE DETAILS, SEE SHEET 25.
 6. FILL ALL PRE-DRILLED INSTALLATION HOLES WITH EXTERIOR GRADE SEALANT PRIOR TO INSERTING SCREWS AND APPLY SEALANT OVER THE HEAD OF SCREWS ONCE PROPERLY SEATED.

TITLE: PERSPECTIVE MULTI-SLIDE PATIO DOOR IMPACT ANCHOR LAYOUT	DATE			
	BY			
NO.	REVISION DESCRIPTION			
DATE: 08/25/23	DWN BY: LMH	CHK BY: SAS	SCALE: NTS	

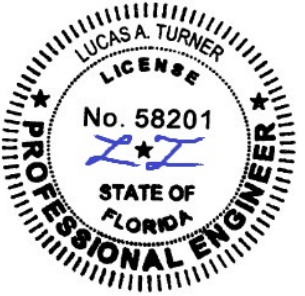

12/12/2023
LUCAS A. TURNER, P.E.
FL PE # 58201
TURNER ENGINEERING & CONSULTING, INC.
(COA # 29779)
2428 OLD NATCHEZ TRACE TRAIL, CAMDEN, TN 38320
PH. 941-380-1574

FL#: **41161**
DWG #: **PGW342**
SHEET: **22 OF 26**

4 TRACK ANCHOR LAYOUT DETAILS BOX FRAME - JAMBS

JAMB - DP60 (+60/-65) IMPACT

PlyGem
WINDOWS & DOORS
Part of the Cornerstone Building Brands Family
433 N. MAIN ST.,
PO BOX 559,
ROCKY MOUNT, VA 24151
PH: 540-484-6348
FX: 540-484-6683

SEE TABLE I, SHEET 2:
ANCHOR ID - A, D, F, G,
H, I, J, K, P, AND Q.

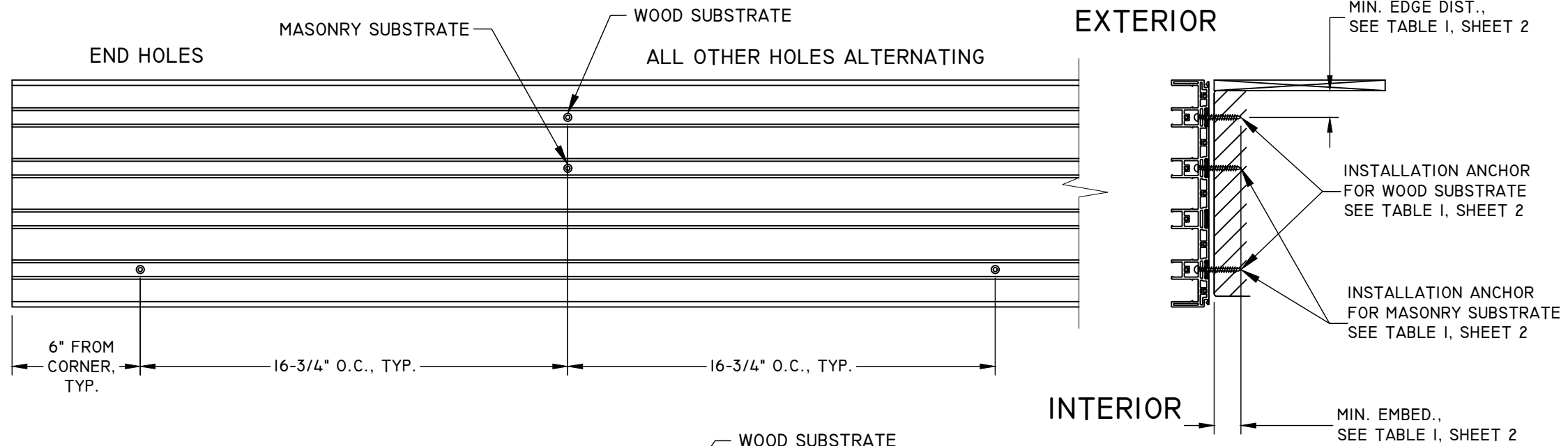

SEE TABLE I, SHEET 2:
ANCHOR ID - L, M, N, AND O.

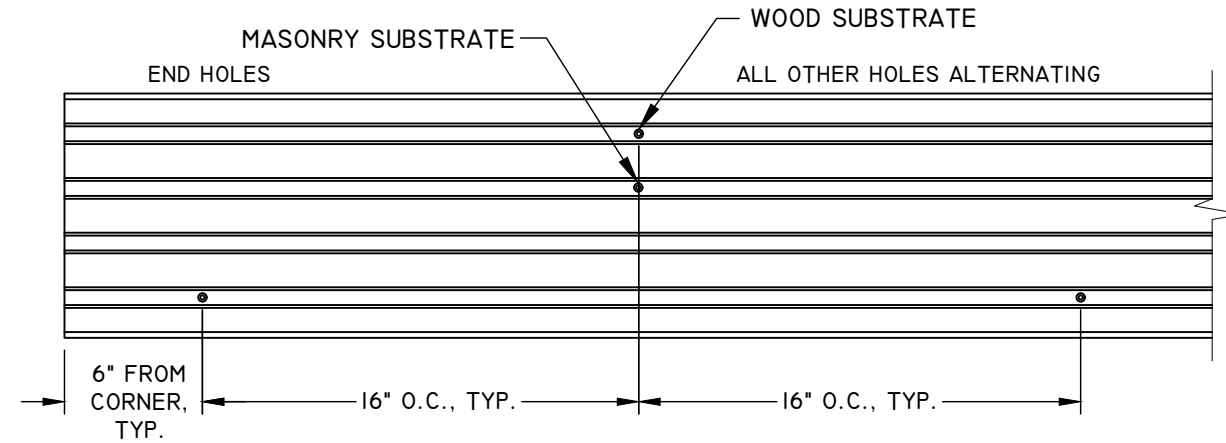

SEE TABLE I, SHEET 2:
ANCHOR ID - B, C, AND E.

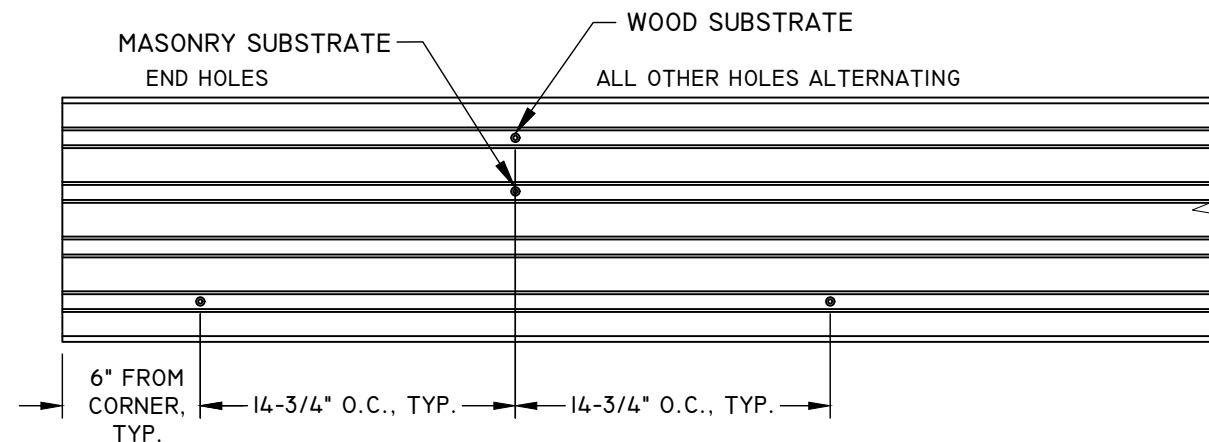

NOTES:

1. INSTALLATION HOLES ARE FABRICATED BY MANUFACTURER.
2. SEE TABLE I, SHEET 2 OR TABLE 2, SHEET 3 FOR FASTENER MINIMUM EDGE DISTANCE, EMBEDMENT AND ON CENTER SPACING.
3. 1X WOOD BUCK BY OTHERS IS OPTIONAL FOR MASONRY APPLICATIONS.
4. 1/4" MAX. SHIM STACK.
5. FILL LEFT & RIGHT PRE-DRILLED JAMB INSTALLATION HOLES - 6" FROM CORNER OF SILL ONLY, WITH EXTERIOR GRADE SEALANT PRIOR TO INSERTING SCREWS AND APPLY SEALANT OVER THE HEAD OF THE SCREWS ONCE PROPERLY SEATED.

NO.	REVISION DESCRIPTION	BY	DATE

TITLE: PERSPECTIVE MULTI-SLIDE PATIO DOOR IMPACT ANCHOR LAYOUT

DATE:	DWN BY:	CHK BY:	SCALE:
08/25/23	LMH	SAS	NTS

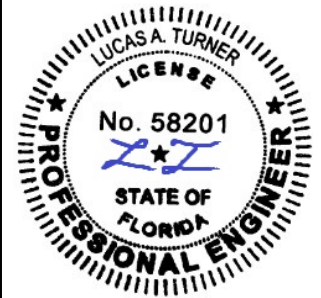

12/12/2023
LUCAS A. TURNER, P.E.
FL PE # 58201
TURNER ENGINEERING &
CONSULTING, INC.
(COA # 29779)
2428 OLD NATCHEZ TRACE
TRAIL, CAMDEN, TN 38320
PH. 941-380-1574

FL#: 41161

DWG #: PGW342

SHEET: 23 OF 26

P-HOOK ANCHOR LAYOUT

DETAIL E4
P-HOOK

MAX. 2" FROM EACH END, TYP.

MAX. 6" FROM EACH END, TYP.

MAX. 12" O.C., TYP.

MAX. 12" O.C., TYP.

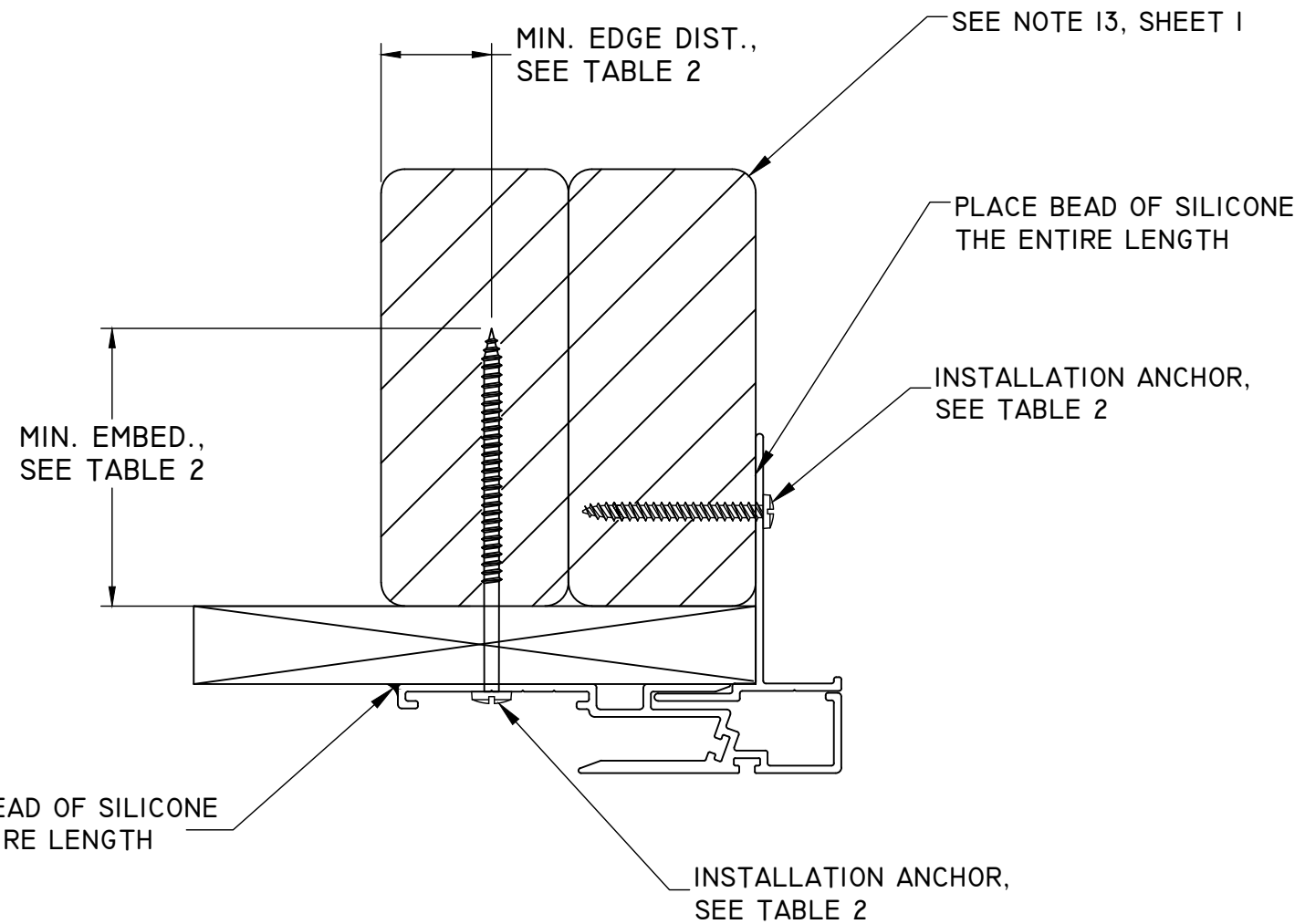
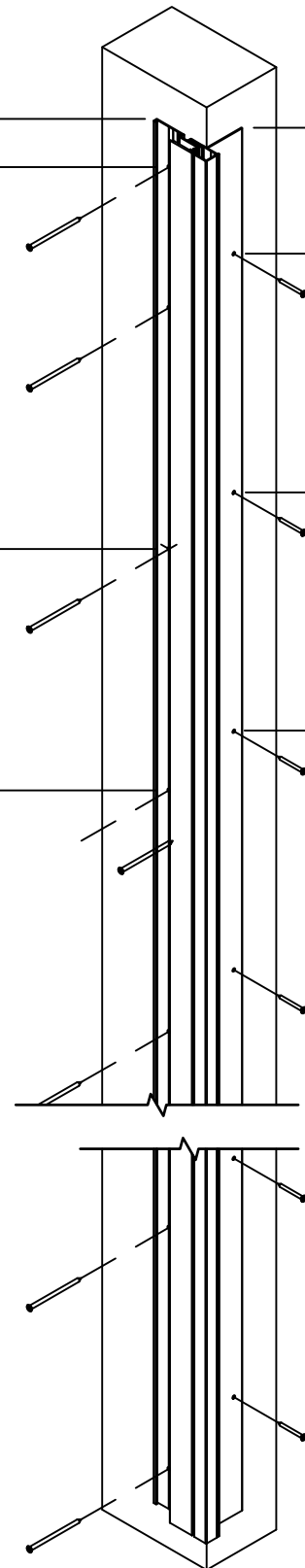
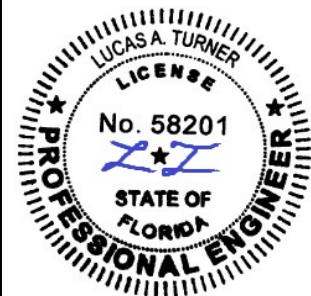

TABLE 2: P-HOOK INSTALLATION FASTENERS TABLE

ID	SUBSTRATE TYPE	ANCHOR TYPE	MIN. EDGE DISTANCE	MIN. EMBED.	MIN. ON-CENTER SPACING
R	CONCRETE (3.05 KSI MIN)	3/16" DEWALT ULTRACON+ COATED CARBON STEEL	1"	1"	3"
S	HOLLOW OR GROUT-FILLED CMU (ASTM C-90)	3/16" DEWALT ULTRACON+ COATED CARBON STEEL	1"	1-1/4"	3"
T	2x MIN. SPRUCE-PIN-FIR WOOD (G=0.42 MIN)	#8 GRADE 5 STEEL WOOD SCRW	1"	1-1/4"	3"
U	16 GAUGE (0.060") MIN. STEEL STUD, 33 KSI MIN. YIELD	#10-16 ITW-TEKS, DEWALT DRIL-FLEX, OR HILTI KWIK-FLEX SELF DRILLING SCREW	1/2"	FULL PLUS 3 THREADS MIN.	3"
V	1/8" ALUM. 6063-T5 MIN. OR 1/8" STEEL 33 KSI MIN.	#10-16 GRADE 5 SELF-TAPPING/DRILLING SCREW	1/2"	FULL PLUS 3 THREADS MIN.	3"

NOTES: -ALL SCREWS SHALL BE PAN OR HEX WASHER HEAD.
-PRE-DRILLING FOR ANCHORS INTO WOOD IS RECOMMENDED.
-CONCRETE/MASONRY SHALL NOT BE CRACKED.

TITLE: PERSPECTIVE MULTI-SLIDE PATIO DOOR IMPACT P-HOOK ANCHOR LAYOUT DETAILS & TABLE 2	DATE	BY	REVISION DESCRIPTION	NO.
	08/25/23	LHM	SAS	NTS



12/12/2023
LUCAS A. TURNER, P.E.
FL PE # 58201
TURNER ENGINEERING & CONSULTING, INC.
(COA # 29779)
2428 OLD NATCHEZ TRACE TRAIL, CAMDEN, TN 38320
PH. 941-380-1574

FL#: **41161**
DWG #: **PGW342**
SHEET: **24 OF 26**

SPLICE DETAILS

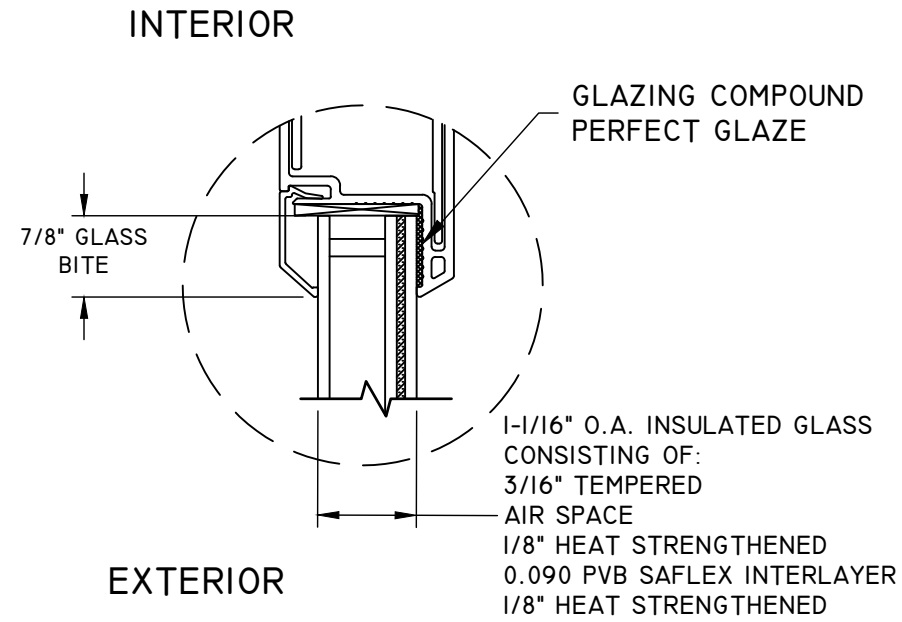

GLAZING DETAIL 1

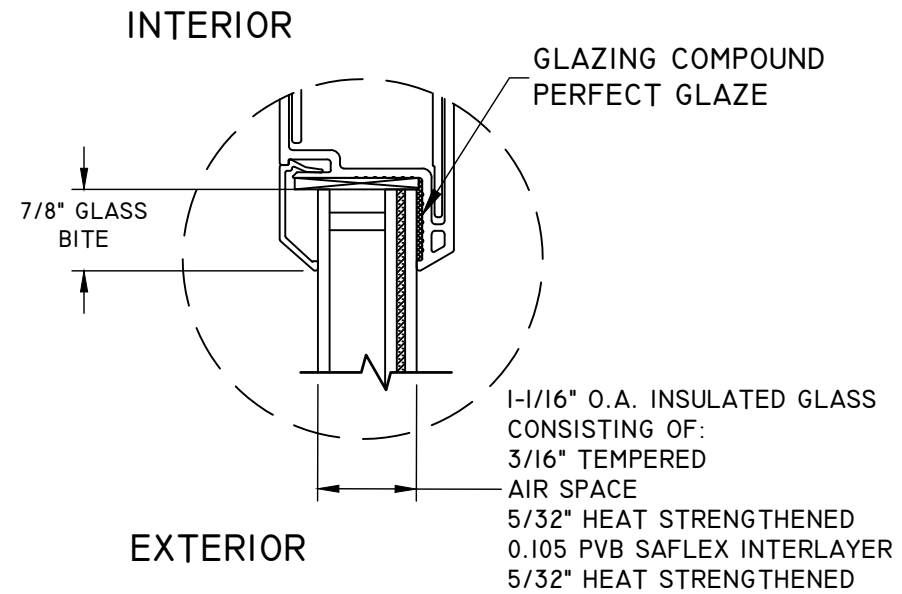

GLAZING DETAIL 2

GLAZING NOTE:
GLASS THICKNESS AND TYPE SHALL COMPLY WITH
ASTM E-1300 GLASS CHART REQUIREMENTS.

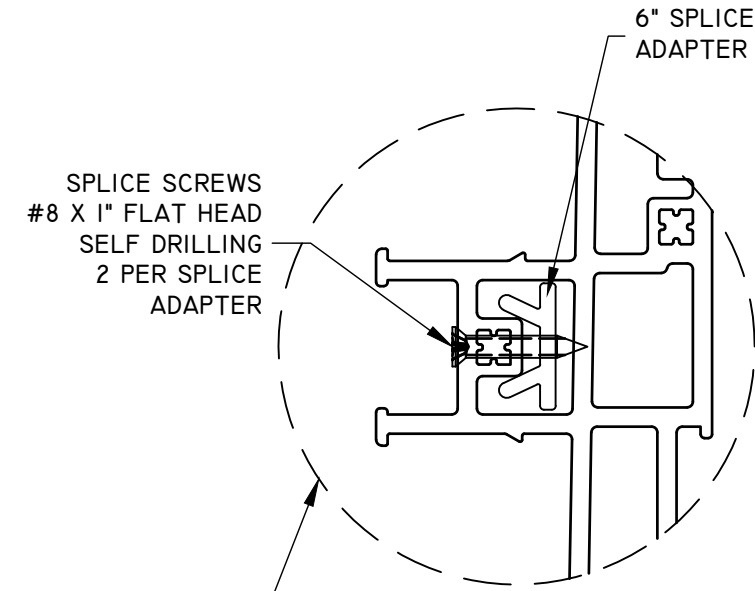

APPLY SILICONE TO THE FACE
OF FRAME PROFILE BEFORE
CONNECTING SPLICE.

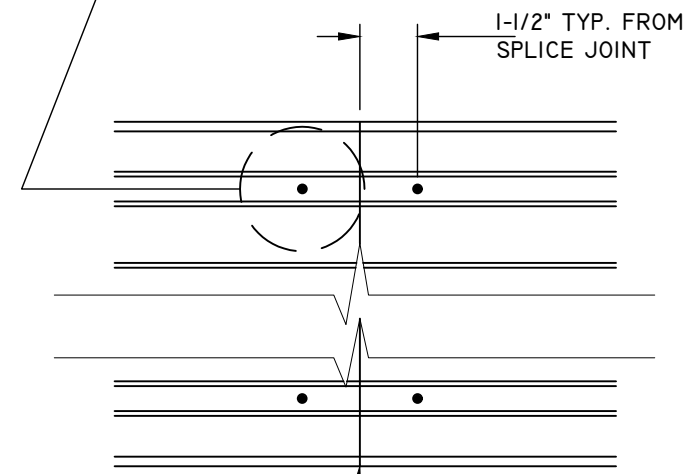

TITLE: PERSPECTIVE MULTI-SLIDE PATIO DOOR IMPACT GLAZING DETAILS & SPLICE DETAILS	DATE			
	BY			
NO.	REVISION DESCRIPTION			

DATE: 08/25/23	DWN BY: LMH	CHK BY: SAS	SCALE: NTS
-------------------	----------------	----------------	---------------

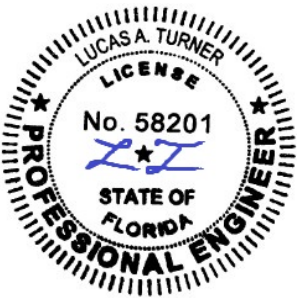

12/12/2023
LUCAS A. TURNER, P.E.
FL PE # 58201
TURNER ENGINEERING &
CONSULTING, INC.
(COA # 29779)
2428 OLD NATCHEZ TRACE
TRAIL, CAMDEN, TN 38320
PH. 941-380-1574

FL#: 41161

DWG #: PGW342

SHEET: 25 OF 26

NAIL FIN SUPPLEMENTAL PATTERN - HEAD AND SILL CENTERED AT INTERLOCK / ASTRAGAL

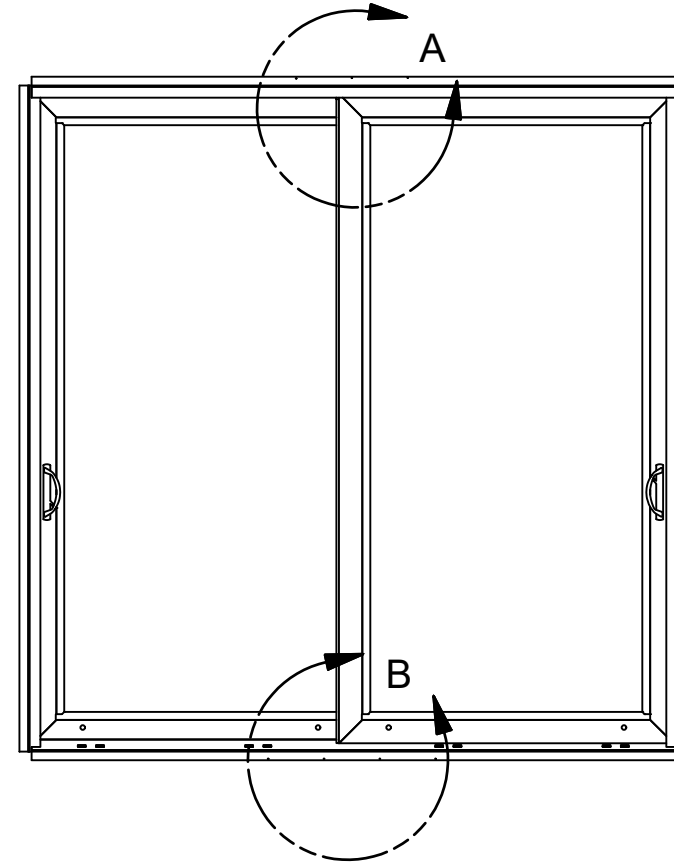
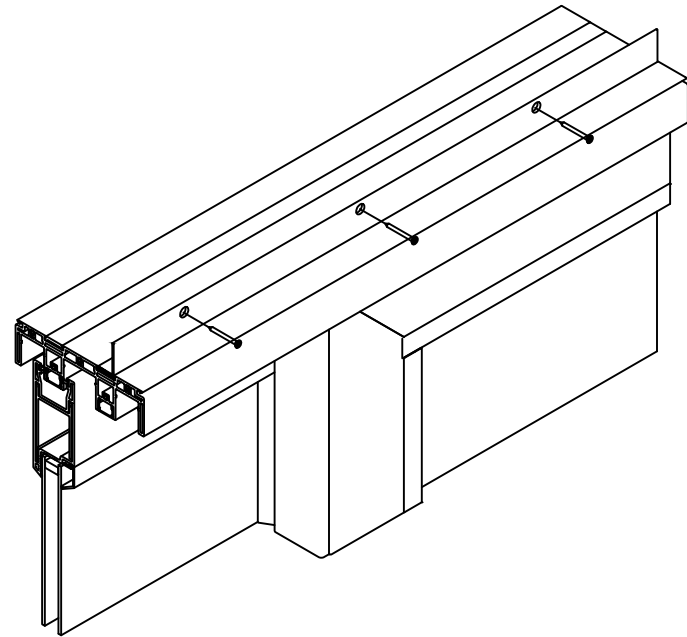

PRE-DRILL 3 - 1/8" NAIL
FIN INSTALLATION HOLES.

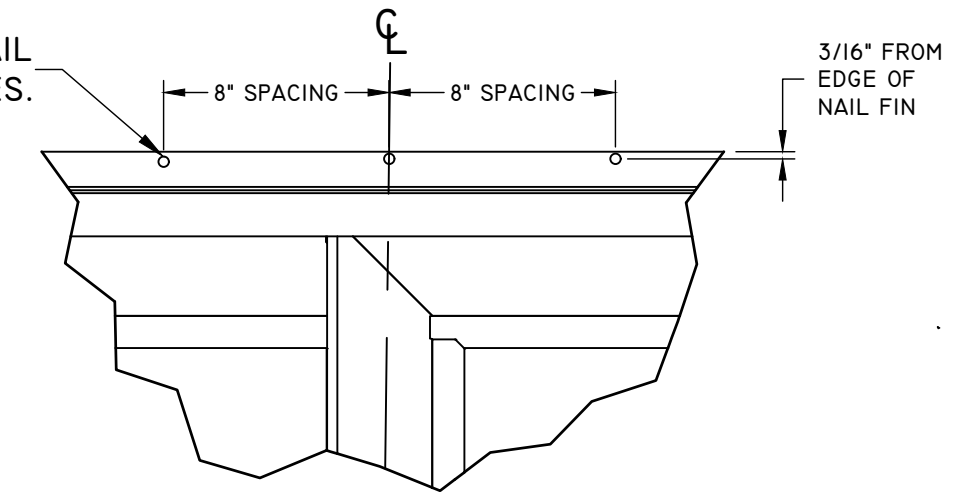

DETAIL A

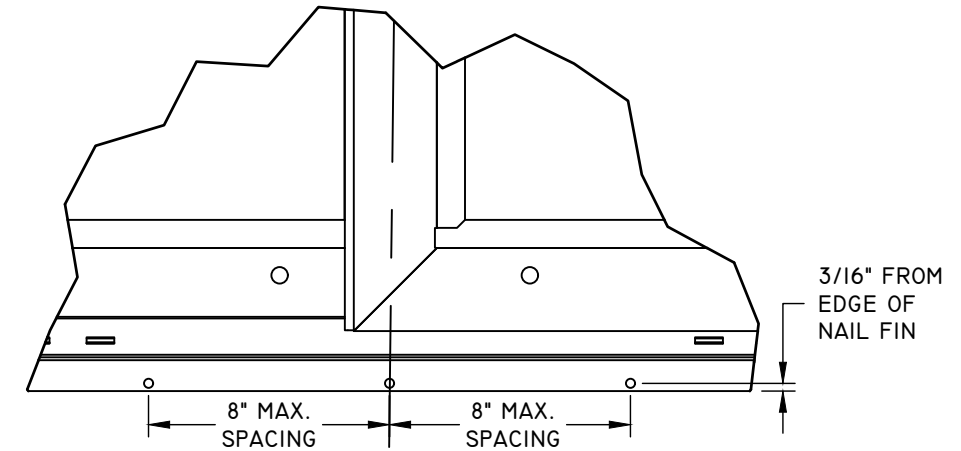

DETAIL B

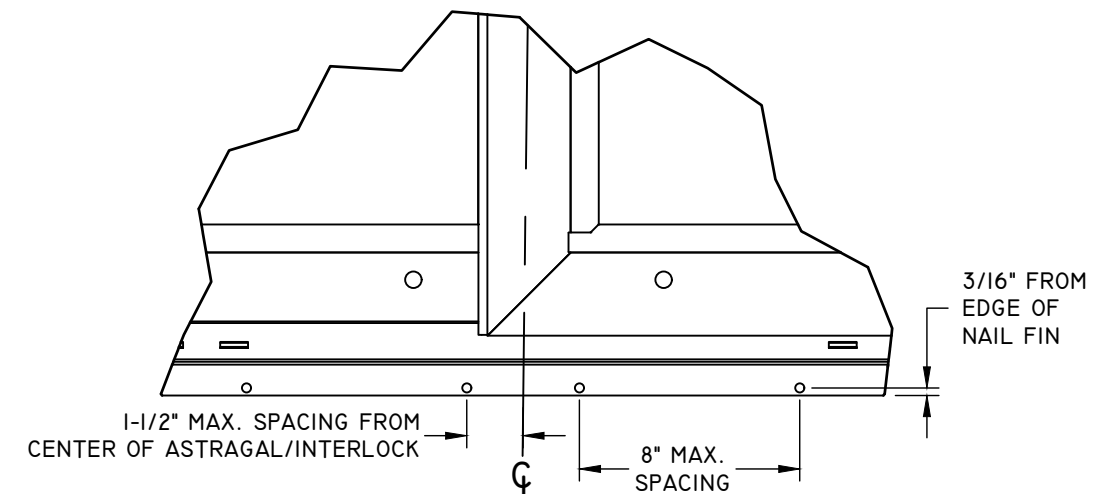

DETAIL B - ALTERNATE
2-TRACK SILL ONLY

TABLE 3: NAIL-FIN INSTALLATION FASTENERS TABLE

ID	SUBSTRATE TYPE	ANCHOR TYPE	MIN. EDGE DISTANCE	MIN. EMBED.	MIN. ON-CENTER SPACING
X	2x MIN. SPRUCE-PIN-FIR WOOD (G=0.42 MIN)	#8 GRADE 5 STEEL WOOD SCRW	5/8"	1-1/2"	3"
Y	16 GAUGE (0.060") MIN. STEEL STUD, 33 KSI MIN. YIELD	#10-16 ITW-TEKS, DEWALT DRIL-FLEX, OR HILTI KWIK-FLEX SELF DRILLING SCREW	1/2"	FULL PLUS 3 THREADS MIN.	3"
Z	1/8" ALUM. 6063-T5 MIN. OR 1/8" STEEL 33 KSI MIN.	#10-16 GRADE 5 SELF-TAPPING/DRILLING SCREW	1/2"	FULL PLUS 3 THREADS MIN.	3"

NOTES: -ALL SCREWS SHALL BE PAN OR FLAT HEAD.
-PRE-DRILLING FOR ANCHORS INTO WOOD IS RECOMMENDED.

TITLE: PERSPECTIVE MULTI-SLIDE PATIO DOOR IMPACT NAIL FIN SUPPLEMENTAL PATTERN	DATE				
	BY				
	REVISION DESCRIPTION				
NO.					
DATE: 08/25/23	DWN BY: LMH	CHK BY: SAS	SCALE: NTS		

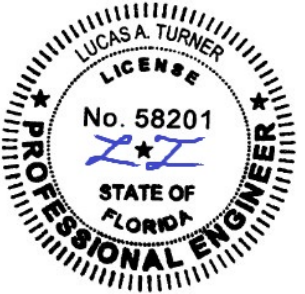

12/12/2023
LUCAS A. TURNER, P.E.
FL PE # 58201
TURNER ENGINEERING &
CONSULTING, INC.
(COA # 29779)
2428 OLD NATCHEZ TRACE
TRAIL, CAMDEN, TN 38320
PH. 941-380-1574

FL#: 41161

DWG #: PGW342

SHEET: 26 OF 26